



**INTENSITY**<sup>®</sup>  
AIR CONDITIONING



# COMMERCIAL SPLIT SYSTEM

COOLING ONLY 220V | 15 and 20 Tons.

IDCES180KF-5, IDCCS090KF-5,  
IDCES240KF-5, IDCCS120KF-5.

# INSTALLATION MANUAL

Thank you very much for purchasing our air conditioner,  
Before using your air conditioner, please read this manual carefully and keep it for future reference.





PRECAUTIONS.....	1
ACCESSORIES (INDOOR UNIT).....	2
INSTALLATING INDOOR UNIT .....	2
INSTALLATING OUTDOOR UNIT.....	6
HEAT INSULATION OF THE PIPE .....	9
INSTALL THE CONNECTIVE PIPE.....	10
INSTALL THE DRAIN PIPE.....	12
ELECTRIC CONNECTION.....	13
ELECTRIC WIRE DIAGRAM.....	15
TRIAL RUN.....	18

# 1. PRECAUTIONS

Precautions before reading the installation manual.

- Read this user manual carefully before installing the equipment.
- The air conditioner must be installed by professional technicians.
- When installing the indoor unit and its accessory pipes, adhere to this user's manual as far as possible.
- Inspect and make sure the piping and cabling are correct before powering on the air conditioner.
- This information may change with the update of this machine, and no further notice will be given for such change.

The safety precautions listed here are divided into two categories. In either case, important safety information is listed which must be read carefully.



## WARNING

Failure to observe a warning may result in death.



## CAUTION

Failure to observe a caution may result in injury or damage to the equipment.

After completing the installation, make sure that the unit operates properly during the start-up operation. Please instruct the customer on how to operate the unit and keep it maintained. Also, inform customers that they should store this installation manual along with the owner's manual for future reference.



## WARNING

- Do not throw or slam the remote controller.
- Operate the remote controller within the receiving scope of the indoor unit, and direct the transmitting part of the remote controller to the receiver of the indoor unit.
- The remote controller should be over 1m away from the television or sound box.
- Do not place the remote controller at a moist place, near the heat sources such as stove, or expose it directly in the sunlight.
- Ensure correct positive and negative poles when loading the batteries.
- Decide the correct way of conveying the equipment.
- Try to transport this equipment with the original package.
- If the air conditioner needs to be installed on a metal part of the building, electric insulation must be performed, and the installation must meet the relevant technical standards of electric devices.
- The appliance must be installed 2.3m above floor.
- The appliance shall not be installed in the laundry.
- Before obtaining access to terminals, all supply circuits must be disconnected.
- The appliance must be positioned so that the plug is accessible.
- The enclosure of the appliance shall be marked by word, or by symbols, with the direction of the fluid flow.
- If the supply cord is damaged, it must be replaced by the manufacture or its service agent or a similarly qualified person in order to avoid a hazard.
- An all-pole disconnection switch having a contact separation of at least 3mm in all poles should be connected in fixed wiring.



## CAUTION

- Install the unit where enough space of installation and maintenance is available.
- Install the unit where the ceiling is horizontal and enough for bearing the weight of the indoor unit.
- Install the unit where the air inlet and outlet are not baffled and are the least affected by external air.
- Install the unit where the supply air flow can be sent to all parts in the room.
- Install the unit where it is easy to lead out the connective pipe and the drain pipe.
- Install the unit where no heat is emitted from a heat source directly.

- Installing the equipment in any of the following places may lead to faults of the equipment (if that is inevitable, consult the supplier):
  - The site contains mineral oils such as cutting lubricant.
  - Seaside where the air contains much salt.
  - Hot spring area where corrosive gases exist, e.g., sulfide gas.
  - Factories where the supply voltage fluctuates seriously.
  - Inside a car or cabin.
  - Place like kitchen where oil permeates.
  - Place where strong electromagnetic waves exist.
  - Place where flammable gases or materials exist.
  - Place where acid or alkali gases evaporate.
  - Other special environments.
- Install the unit where enough space of installation and maintenance is available.
- Install the unit where the air inlet and air outlet are free from obstacles and strong wind.
- Install the unit in a dry and well ventilated place.
- Install the unit where the bearing surface is level and can bear weight of the unit, and is suitable for installing the unit horizontally without increasing noise or vibration.
- Install the unit where the operation noise and the expelling of air do not affect neighbours.
- Install the unit where no flammable gas is leaked.
- Install the unit where it is convenient for pipe connection and electric connection.

## 2. ACCESSORIES (INDOOR UNIT)



### NOTE

- If in the wire control mode, the accessories do not include display panel assembly remote controller or mounting bracket.

Table.2-1

Accessory name	Qty.	Shape	Purpose
Owner's manual	1	—	—
Installation manual	1	This manual	—
Restriction assembly	1	—	Connect to system
Water connective pipe	1	—	Connect to water drainage pipe
Display board subassembly	1	—	Connect to control signal
Protective sleeve for refrigerant inlet and outlet pipes	2		
Remote controller	1		
AAA battery	2		
Copper connective pipe	4	—	Connect to Refrigerant pipe

Table.2-2

Accessory name	Qty.	Shape	Purpose
Owner's manual	1	—	—
Installation manual	1	This manual	—
Water connective pipe	1	—	Connect to water drainage pipe
Remote controller Owner's Manual	1		Owner's Manual
Remote controller	1		
AAA battery	2		
Copper nut (96000 unit not attached)	1		Connect to refrigerant pipe

## 3. INSTALLING INDOOR UNIT

### 3.1 Duct type

#### 3.1.1 Installation space

Ensure enough space required for installation and maintenance.

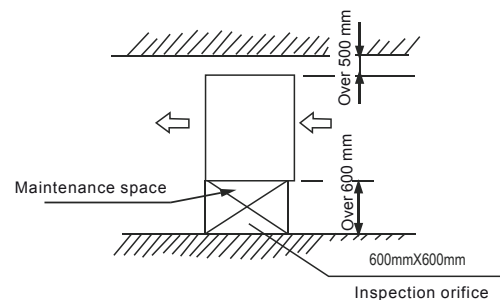

Fig. 3-1

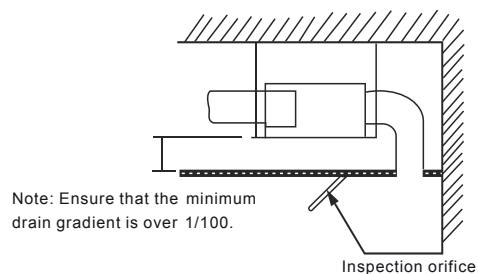

Fig. 3-2

#### 3.1.2 Install $\Phi 10$ Pendant Bolts Or Ground Bolts

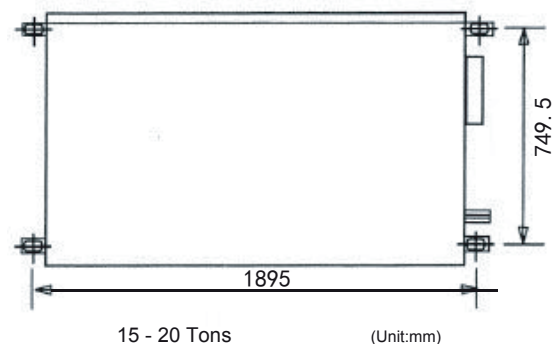

Fig. 3-3

Fig. 3-3

- Use  $\Phi 10$  or bigger screws. The screw material is high-quality carbon steel (whose surface is zinc plated or undergoes other rustproof treatment) or stainless steel.
- The treatment of the ceiling varies between buildings. For detailed measures, consult with the fitting-out staff.
- Fix the pendant bolts firmly and reliably in light of the specific situation.
- Installation of the pendant bolt in different environments.

#### A. Wooden structure

Put rectangular sticks across the beams, and set pendant bolts.

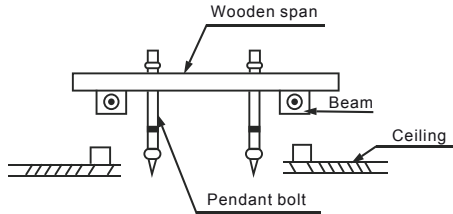

Fig. 3-4

#### B. New concrete roughcast

Use embedded bolts, embedded pulling plugs, and embedded stick harness.

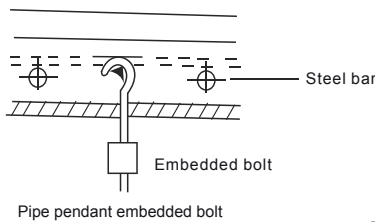

Fig. 3-5

#### C. New concrete roughcast

Set it with embedded bushes or embedded bolts.

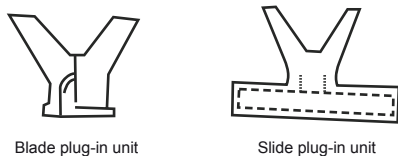

Fig. 3-6

#### D. Steel beam and girder structure

Set and use supportive angle steel.

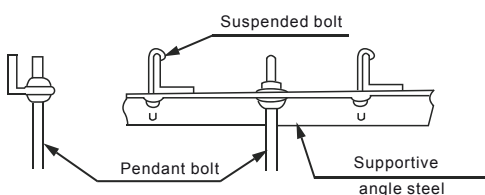

Fig. 3-7

### 3.1.3 Suspending The Indoor Unit

Use a hoisting device to hoist the indoor unit, align it with the installation screw, adjust the horizontality and then tighten it.

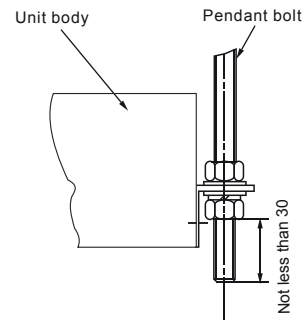

Fig. 3-8

### 3.1.4 Design And Connection Of Duct

- The duct design must comply with the national heating air conditioner pipeline design specifications.
- The duct accessories and materials must be produced by professional manufacturers.
- In order to prevent air flow shorting, do not keep the air inlet pipe near the air outlet pipe.
- Install a filter at an easy-to-maintain place such as intake pipe. (Otherwise, the duct will gather on the air heat exchanger and lead to fault and water leak of the air conditioner.)
- In order to suppress noise effectively, install noise suppression and sound insulation devices, especially in the noise-sensitive spaces such as meeting rooms.
- For connection of the flange plane, use non-flammable canvas adapter to prevent transmission of vibration. For its size, see the indoor unit outline diagram. Use M6X20 screws (configured on site) for connection.
- All pipelines must be connected closely and soundly without leak of air. The pipelines must be adiabatic and free from condensation.

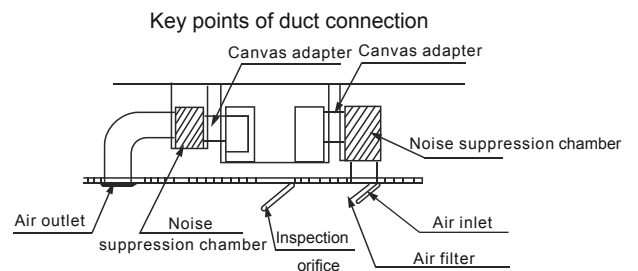

Fig. 3-9

### 3.1.5 Install the drainpipe

#### 1. Install the indoor unit drainpipe

Install a drain stream trap in the drain pipe to prevent water from overflowing. (The drain pipe absorbs the odor. When the outside static pressure is high (especially the air inlet), it is difficult to drain the water.)

Drainage should be natural. When constructing, the outside pipe of outdoor unit should be inclined ( $1/50 \sim 1/100$ ).

The bending part of drain pipe should be fewer than 2. Furthermore, to reduce the depositing dust, avoid bending the pipe as possible as you can.

Make sure there is no dust or rubbish falling into indoor unit drain elbow and drain pipe.

After installation, remove the checking panel, pour some water in the drain elbow to see whether it drains smoothly.

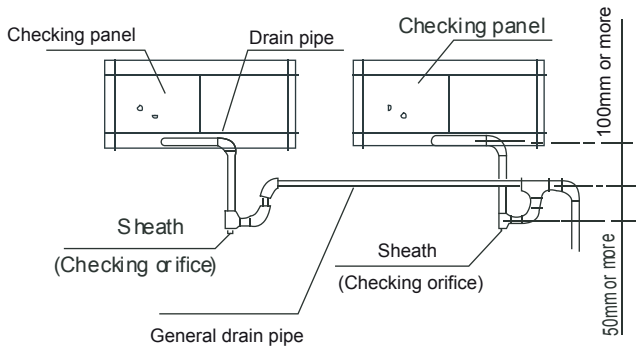

Fig.3-10



**CAUTION**

Rubbish is easy to accumulate at drain stream trap. Make sure to install a plug or other things which is easy to clean.

2. Test draining

Open the clapboard of indoor unit, pour the water in to see whether it drain smoothly and whether there is water leakage.

3. Heat insulation

After confirming that drainage is smoothly and there is no leakage, wrap the drainpipe with insulation material, or there will be condensed water.

3.1.6 Dimension (Unit:mm)

■ 15 & 20 Tons.

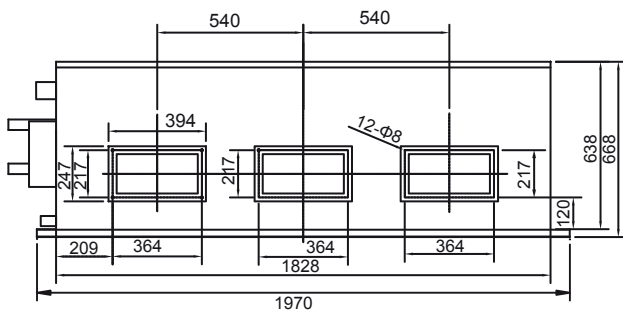

Front view (Air supply outlet)

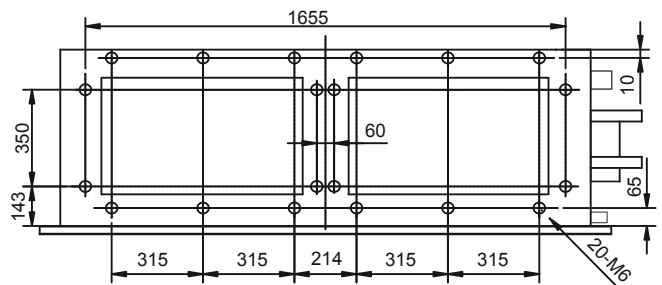

Rear view (Air return vent)

Fig.3-13

Fig.3-11

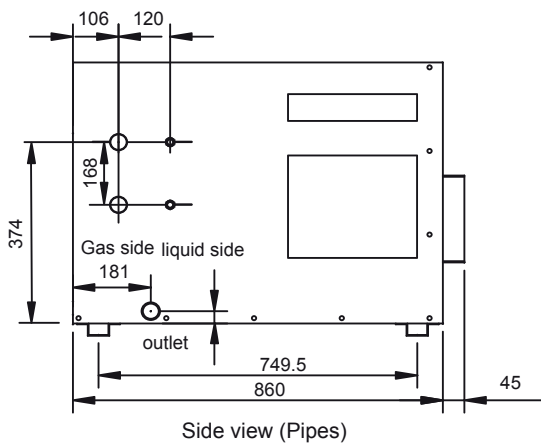

Side view (Pipes)

Fig.3-12

## 4. INSTALLATING OUTDOOR UNIT

### 4.1 Important: Construction Checkpoints

#### ■ Installation

Check the model and name to avoid mistaken installation.

#### ■ Refrigerant pipe

- The refrigerant pipes must have the specified diameter.
- Nitrogen of a certain pressure must be filled into the refrigerant pipe before welding.
- The refrigerant pipe must undergo heat insulation treatment.
- After the refrigerant pipe is installed completely, the indoor unit cannot be powered on before performing the airtight test and creating a vacuum.

#### ■ Refrigerant pipe

The refrigerant pipe must undergo the airtight test [with 2.94MPa (30kgf/cm<sup>2</sup>G) nitrogen].

#### ■ Creating a vacuum

Be sure to use the vacuum pump to create a vacuum of the connective pipe at both air side and liquid side concurrently.

#### ■ Refrigerant replenishment

- If the pipe is longer than the reference pipe, the refrigerant replenishment quantity for each outdoor unit should be calculated through the formula obtained according to the actual length of the pipe.
- Record the refrigerant replenishment quantity, actual length of pipe and the height difference of the indoor & outdoor units onto the operation confirmation table (on the electric control box) of the outdoor unit in advance for future reference.

#### ■ Electric wiring

- Select the power supply capacity and wire size according to the design manual. The power wire size of the air conditioner should be greater than that of ordinary motors.
- In order to prevent misoperation of the air conditioner, do not interleave or entwine the power cable (208 230V 3N~ 60Hz) with the connection wires (low-voltage wires) of the indoor/outdoor unit.
- Power on the indoor unit after performing the airtight test and making a vacuum.

#### ■ Trial run

Perform the trial run only after the outdoor unit has been powered on for over 12 hours.

### 4.2 Installation Space

- When installing the unit, leave a space for maintenance shown in the following figure. Install the power supply at the side of the outdoor unit. For installation procedure, see the relevant installation manual.

Ensure enough space for installation and maintenance.(see Fig.4-1 and Fig.4-2)

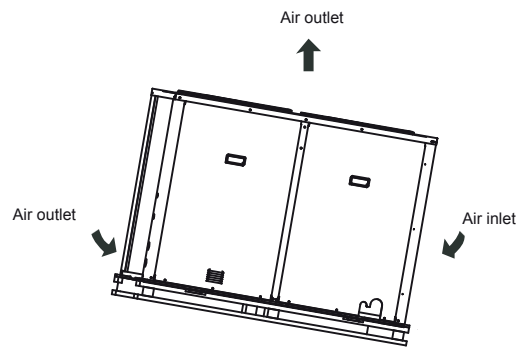
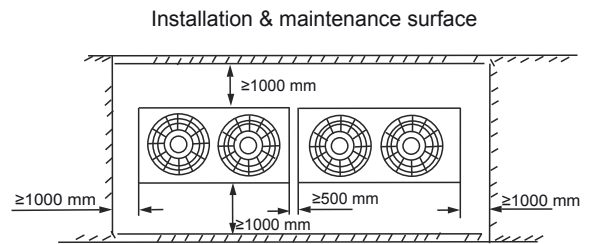

Fig.4-1



Top view of the outdoor unit (multiple units installed)

Fig.4-2



### NOTE

- In case any obstacles exist above the outdoor unit, such obstacles must be 2000mm above the outdoor unit.
- If miscellaneous articles are piled around the outdoor unit, such articles must be 400mm below the top of the outdoor unit.

### 4.3 Convey Outdoor Unit

- Use 4 steel ropes of  $\Phi 6$ mm or bigger size to hoist the outdoor unit and convey it into the room.
- In order to prevent scratch and deformity the outdoor unit, apply a guard board to the surface of contact between the steel wire and the air conditioner.
- Remove the cushion for use in the transport after finishing the transport.

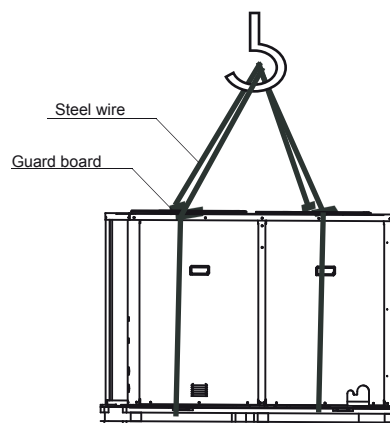

Fig.4-3

## 4.4 Installing The Outdoor Unit

- As shown in Fig.4-4, leave an interval of 100mm between the outdoor units.

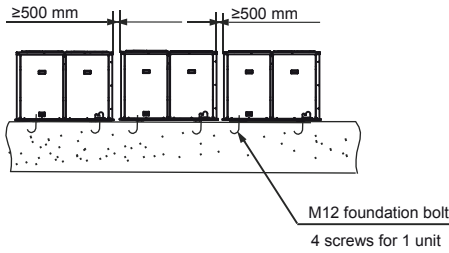

Fig.4-4

- The distance of the foundation bolt is shown in Fig. 4-5.

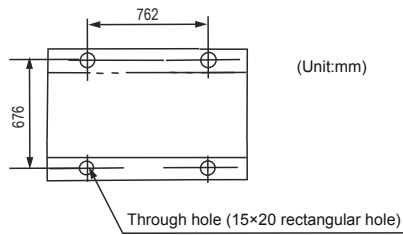

Fig.4-5

- Snow protection facilities must be installed in the snowfall areas. (See the right figure) (in case the snow protection facilities are incomplete, faults may occur). In order to prevent influence caused by snow, set up raised pavilion, and install snow protection sheds at the air inlet and air outlet.

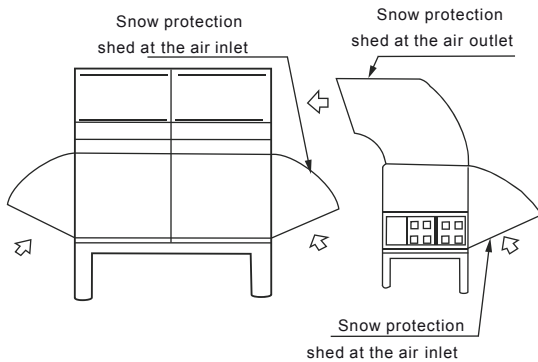

Fig.4-6

## 4.5 Refrigerant Pipe

- The refrigerant pipe adapter is located inside the outdoor unit. So remove the right front board first. (three M5 screw)
- When the pipe is connected from the front side, the pipe can be led out through the right front board.
- As shown in Fig.4-7, when brazing the indoor and outdoor connective lines, pad a sheet metal under the valve avoids the flame burning the chassis.

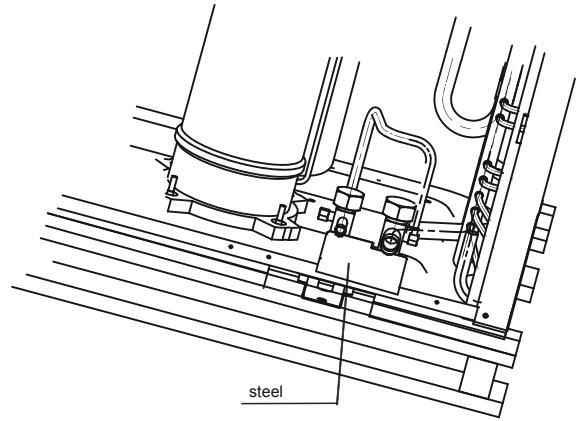

Fig.4-7



### NOTE

- When welding the refrigerant pipe, in order to prevent internal oxidation of the pipe, nitrogen must be filled in. Otherwise, the oxidized chips may block refrigerating circulatory system.

## 4.6 Size Of Outdoor Unit Pipes And Piping Methods

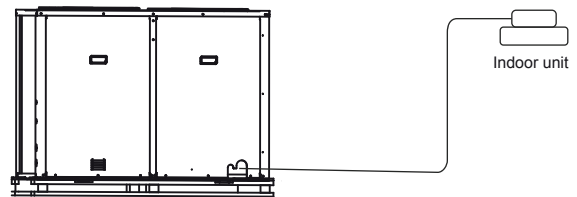

Fig.4-8

- Size of outdoor unit pipes and piping methods

Table.4-1

Capacity	Gas side mm (in)	Liquid side mm (in)
15 Tons.	Φ 25(7/8)	Φ 9.52 (3/8)
20 Tons.	Φ 25(1)	Φ 12.7 (1/2)

- Allowed length of refrigerant pipe and height difference

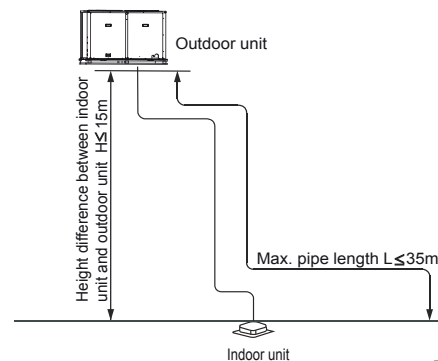

Fig.4-9



Table.4-2

		Allowed value
Max. actual length of pipe (L)		35m
Max. height difference between indoor unit and outdoor unit (H)	Outdoor (upper)	15m
	Outdoor (lower)	20m

■ Floor Type

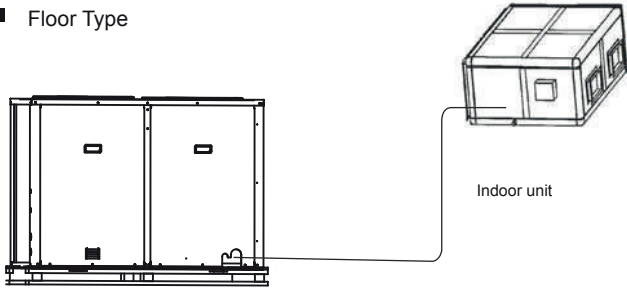

Fig.4-8

### 4.7 Airtight Test

After the pipes between the indoor unit and the outdoor unit are connected, replenish compressed nitrogen to perform airtight test.



**NOTE**

- The airtight test is performed by using the compressed nitrogen [2.94MPa(30kg/cm<sup>2</sup>G)].
- Tighten the spool of the gas valve and liquid valve before compressing the nitrogen.
- Compress the nitrogen at the air vent of the gas valve.
- The gas valve and liquid valve are closed in the process of compressing the nitrogen.
- Do not use oxygen, flammable gas or toxic gas in the airtight test.

### 4.8 Use A Vacuum Pump To Create A Vacuum

- Use a vacuum pump to make a vacuum. Do not use refrigerant gas to expel air.
- When making the vacuum, start from the air side.

### 4.9 Open All Valves

### 4.10 Refrigerant Replenishment Quantity

According to the diameter and length of the connective liquid-side pipe of the outdoor unit and indoor unit, calculate the refrigerant replenishment quantity. The refrigerant for replenishment is R410A.

Table.4-3

Diameter of liquid-side pipe	Quantity of refrigerant replenished for 1 m pipe length
Φ 9.52/12.7	0.06 kg

### 4.11 Remove Trash And Moist In The Pipe

- Trash and foreign matters may come into the pipe in the process of installing the refrigerant pipe. Be sure to blow them off with nitrogen before connecting the pipe to the outdoor units.
- Use high-pressure nitrogen to clean the pipelines. Do not use the refrigerant of the outdoor unit for cleaning.

### 4.12 Schematic Diagram Of Connection Between Indoor Unit And Outdoor Unit

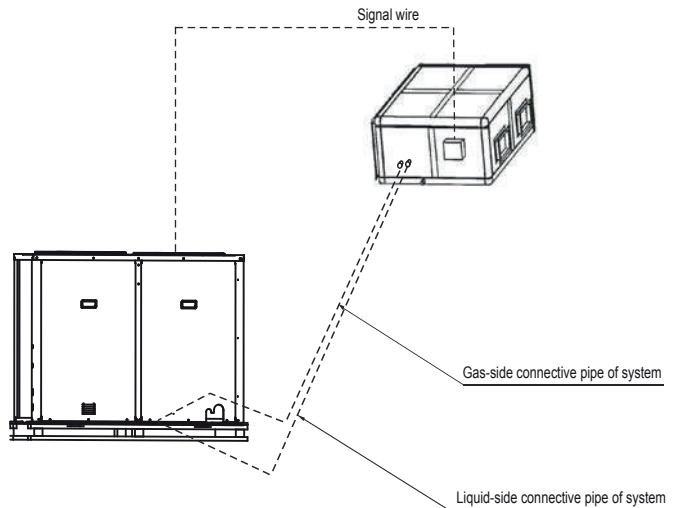

Fig.4-10

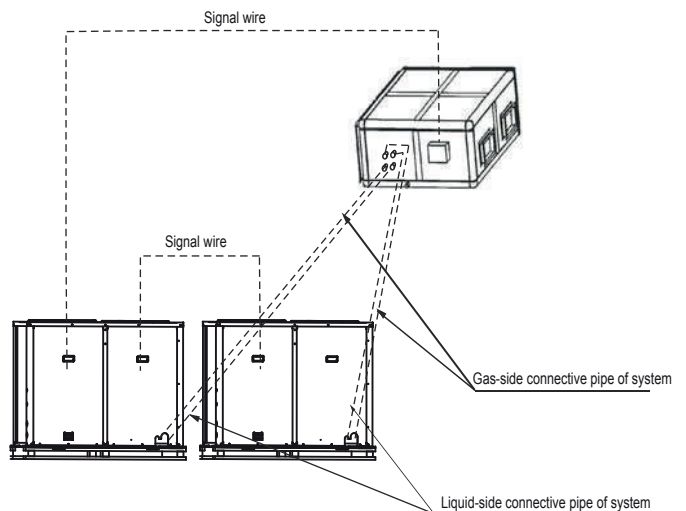

Fig.4-11

## 4.13 Refrigerant Leak Precautions

This air conditioner uses refrigerant R410A. The R410A is safe refrigerant which is harmless and non-flammable. The room for placing the air conditioner should have a proper space. Even if refrigerant leakage occurs, the density threshold will not be crossed. Additional measures may also be taken.

- Density threshold: Density of the Freon gas that does not harm the human body. Density threshold of R410A: 0.3 [kg/m<sup>3</sup>]
- Calculate the total quantity of refrigerant to be replenished (A [kg]). Total refrigerant quantity for 10HP = refrigerant replenishment quantity upon shipment (11[kg]) + additional refrigerant replenishment corresponding to the pipe length
- Calculate out the indoor volume (B[m<sup>3</sup>]) (according to the minimum volume)
- Calculate out the refrigerant density:
 
$$\frac{A[\text{kg}]}{B[\text{m}^3]} \leq \text{Density threshold: } 0.3 [\text{kg/m}^3]$$
- Measures against crossing of the refrigerant density threshold
- In order to keep the refrigerant density below the threshold value, please install a mechanic ventilation device. (perform ventilation often)
- In case frequent ventilation is impossible, please install the leakage detection alarm device linked with the mechanical ventilation device.

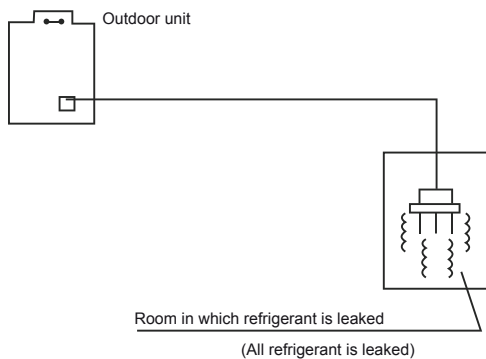

Fig. 4-12

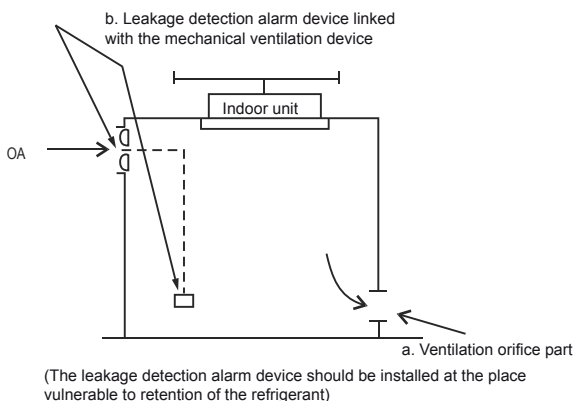

Fig. 4-13

## 4.14 Completing The Connection System Name

In case multiple systems are set, in order to identify the connection system of the indoor unit and outdoor unit, it is necessary to give name to each system, and mark it onto the nameplate on the electric control box cover of the outdoor unit.



## NOTE

- The indoor unit and outdoor unit are categorized into system A and system B. When installing and connecting the indoor unit and outdoor unit, identify the label carefully, and make sure that indoor unit corresponds to the outdoor unit exactly. Otherwise, it may lead to fault of the air conditioner.
- Model of indoor unit. Room name  
Example: The first system indoor unit (A) of the 2nd floor is recorded as: 2F 1A

## 5. HEAT INSULATION OF THE PIPE

### 5.1 Heat Insulation Of The Pipe

In order to prevent faults caused by condensate of the refrigerant pipe and drain pipe, perform condensate prevention and heat insulation properly.



## CAUTION

- If it is forecast that high humidity/temperature environment (condensate temperature is over 23°C) may exist in the ceiling, e.g., inside the ceiling with slab, ceiling which is in the same environment as the outdoor air, it is necessary to apply 10mm or thicker adiabatic wool (16~20kg/m<sup>2</sup>) to the refrigerant pipe and the drain pipe in addition to applying the general heat insulation materials. Enough heat insulation materials should also be applied to the refrigerant joint and the pipe joint.

### 5.2 Heat Insulation Of The Drain Pipe

- Be sure to entwine heat insulation materials round the drain pipe which runs through the room.
- Carry through heat insulation for the drain pipes thoroughly.

### 5.3 Heat Insulation Of The Refrigerant Pipe

- Please use heat-resistant materials as heat insulation materials of the air-side pipe. (e.g., EPT)
- Cover heat insulation materials separately at the liquid side and the air side. Moreover, perform heat insulation thoroughly for the air-side pipes of the indoor unit, and prevent water from dripping outside the unit.

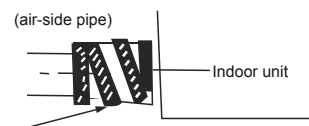

Fig. 5-1

- After applying the auxiliary heat insulation materials, use vinylresin tape to seal it lest water leak.

## 6. INSTALL THE CONNECTIVE PIPE

### 6.1 Preparation Before Installation

- Check the height difference between the indoor unit and the outdoor unit, and check the length and number of bends of the refrigerant pipeline, which must meet the following requirements:  
Max. height difference.... 15 m (If the height difference is greater than 5m, it is best to put the outdoor unit below the indoor unit)  
Max. pipeline length.....35 m  
Max. number of bends.....15
- In the process of installing the connective pipe, do not let the air, dust or foreign substance intrude into the pipeline system.
- Install the connective pipe only after fixing the indoor and outdoor units.
- Keep dry when installing the connective pipe. Do not let moist intrude into the pipeline system.

### 6.2 PRECAUTIONS DURING BRAZING OF LINES

All outdoor unit and evaporator coil connections are copper-to-copper and should be brazed with a phosphorous-copper alloy material such as Silfos-5 or equivalent. DO NOT use soft solder. The outdoor units have reusable service valves on both the liquid and vapor connections. The total system refrigerant charge is retained within the outdoor unit during shipping and installation. The reusable service valves are provided to evacuate and charge per this instruction. Serious service problems can be avoided by taking adequate precautions to assure an internally clean and dry system.



#### CAUTION

Dry nitrogen should always be supplied through the tubing while it is being brazed, because the temperature required is high enough to cause oxidation of the copper unless an inert atmosphere is provided. The flow of dry nitrogen should continue until the joint has cooled. Always use a pressure regulator and safety valve to insure that only low pressure dry nitrogen is introduced into the tubing. Only a small flow is necessary to displace air and prevent oxidation.

### 6.3 PRECAUTIONS DURING BRAZING SERVICE VALVE

Precautions should be taken to prevent heat damage to service valve by wrapping a wet rag around it as shown in Fig. 6. Also, protect all painted surfaces, insulation, during brazing. After brazing cool joint with wet rag.

Valve can be opened by removing the plunger cap and fully inserting a hex wrench into the stem and backing out counter-clockwise until valve stem just touches the chamfered retaining wall.

Connect the refrigerant lines using the following procedure:

1. Remove the cap and Schrader core from both the liquid and vapor service valve service ports at the outdoor unit. Connect low pressure nitrogen to the liquid line service port.

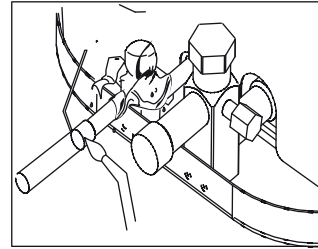

Fig. 6-1

2. Braze the liquid line to the liquid valve at the outdoor unit. Be sure to wrap the valve body with a wet rag. Allow the nitrogen to continue flowing. Refer to the Tabular Data Sheet for proper liquid line sizing.
3. Carefully remove the rubber plugs from the evaporator liquid and vapor connections at the indoor coil.
4. Braze the liquid line to the evaporator liquid connection. Nitrogen should be flowing through the evaporator coil.
5. Slide the plastic cap away from the vapor connection at the indoor coil. Braze the vapor line to the evaporator vapor connection. Refer to the Table 1 for proper vapor line sizing.
6. Protect the vapor valve with a wet rag and braze the vapor line connection to the outdoor unit. The nitrogen flow should be exiting the system from the vapor service port connection. After this connection has cooled, remove the nitrogen source from the liquid fitting service port.
7. Replace the Schrader core in the liquid and vapor valves.
8. Leak test all refrigerant piping connections including the service port flare caps to be sure they are leak tight. DO NOT OVER TIGHTEN (between 40 and 60 inch -lbs. maximum).
9. Evacuate the vapor line, evaporator and the liquid line, to 500 microns or less.



#### NOTE

1. Tube diameters are for lengths up to 50 equivalent ft and/or 20 ft vertical differential.
2. Do not increase or decrease tubing sizes.



#### NOTE

Line set and indoor coil can be pressurized, to 250 psig with dry nitrogen and leak tested with a bubble type leak detector. Then release the nitrogen charge. Do not use the system refrigerant in the outdoor unit to purge or leak test.

10. Replace cap on service ports. Do not remove the flare caps from the service ports except when necessary for servicing the system.



#### CAUTION

Do not connect manifold gauges unless trouble is suspected. Approximately 3/4 ounce of refrigerant will be lost each time a standard manifold gauge is connected.

11. Release the refrigerant charge into the system. Open both the liquid and vapor valves by removing the plunger cap and with an hex wrench back out counter-clockwise until valve stem just touches the chamfered retaining wall.

12. Replace plunger cap finger tight, then tighten an additional 1/12 turn (1/2 hex flat). Cap must be replaced to prevent leaks.



#### WARNING

Never attempt to repair any brazed connections while the system is under pressure. Personal injury could result.

See "System Charge" section for checking and recording system charge.

## 6.4 Expelling Air

- From the following table, select a method of expelling air.

Table 6-2

Length of connective pipe (single pass)	Procedure of expelling air
Less than 5m	Use vacuum pump
5~15m	Use vacuum pump

- If the air conditioner is relocated, be sure to use a vacuum pump or refrigerant tank to expel air.
- Use a vacuum pump to expel the air (Fig. 6-3): (For method of using the manifold valve, see the operation manual of manifold valve)
  - Loosen and remove the maintenance orifice nut of valve A, and connect the filler hose of the manifold valve to the maintenance orifice of valve A (tighten both valve A and valve B).
  - Connect the filler hose adapter to the vacuum pump.
  - Open the low pressure (Lo) handle of the manifold valve completely.
  - Start the vacuum pump to extract air. At the beginning of extracting air, slightly loosen the maintenance orifice nut of valve B, check whether any air enters it (the vacuum pump noise changes, and the multimeter indicates from negative to 0). Then tighten this maintenance orifice nut.
  - Upon completion of vacuuming, tighten the low pressure (Lo) handle of the manifold valve completely and stop the vacuum pump. Keep extracting air for over 15 minutes. Check whether the multimeter points at  $-1.0 \times 10^{-1} \text{ Pa}$  ( $-76 \text{ cmHg}$ ).
  - Loosen and remove the square-head cover of valves A and B. After opening valves A and B completely, tighten the square-head cover of valves A and B.
  - Remove the filler hose off the maintenance orifice of valve A, and then tighten the nut.

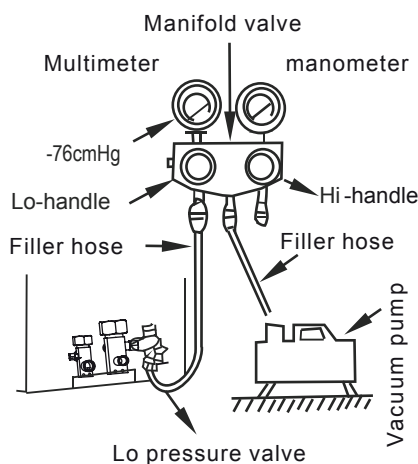

Fig. 6-3

- Procedure of using stop valve
  - Open the spool until it touches the stop block. Do not attempt to open further.
  - Use a spanner or a similar tool to tighten the bonnet. The bonnet tightening torque is shown in above Table "Tightening torque".
  - Upon completion of installation, open all valves before trial run. Each unit has two valves of different sizes located at the outdoor unit side. Of the two valves, one is gas valve and the other is liquid valve. The procedure of opening/closing the valve is shown in the right figure (Fig. 6-5).
- Procedure of opening the valve: Open the square-head cover, use a spanner to capture the square head and open it thoroughly. Then tighten the square-head cover.
- Procedure of closing the valve: Same as the procedure of opening the valve, but rotate the spanner clockwise thoroughly.

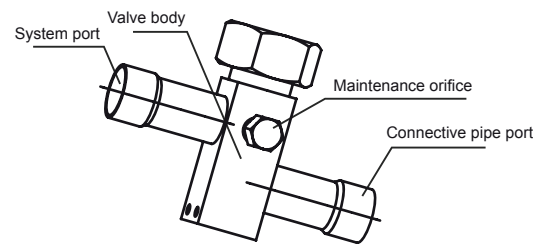

Fig. 6-5

## 6.5 Leak Detection

- Use soap water or a leak detector to check whether gas leakage exists at the adapters.

## 6.6 Heat Insulation

- Use heat insulation materials to wrap the part protruding outside the flared pipe joint and the refrigerant pipe of the liquid pipe and the gas pipe, and ensure that no gap exists between them.
- Imperfect heat insulation may lead to condensate drips.

## 7. INSTALL THE DRAIN PIPE

### Duct Type

- Install the drain pipe of the indoor unit

In order to prevent drain overflow, install a drainage controller at place 1 of the drain pipe. (The drainage controller is designed to smoothen the drainage when the static pressure outside the unit is high, especially at the air inlet, in addition to remove stink through the drain pipe.)

The drain of water is natural. In the construction, the external pipe of the outdoor unit slants downward at a gradient of 1/50~1/100.

The number of bends and folds of the drain pipe should not exceed 2. Try to avoid bends in order to prevent trash accumulation.

In the construction, do not drop trash into the drip tray or drain pipe of the indoor unit.

Upon completion of installing the drain pipe, remove the inspection panel. Put water into the drip tray to check whether the water can be drained levelly and steadily.

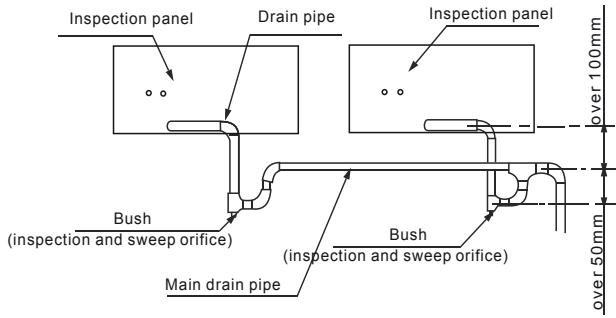

Fig. 7-1

**NOTE**

- Drain pipe trash gains easily at the drainage controller. Be sure to install a stopper and a structure that cleans up trash easily.
- Trial draining of the drain pipe  
Open the side panel of the indoor unit, fill water inward, and check whether the water can be drained smoothly. Check water leak at the joint.
- Heat insulation of drain pipe  
After making sure that the water drains smoothly and no water is leaked, use adiabatic wool bushes to preserve heat of the drain pipe. Otherwise, condensate will occur.

## 8. ELECTRIC CONNECTION

**CAUTION**

- Use special power supply for the air conditioner. Design power supplies specific to the indoor unit and outdoor unit. The supply voltage must comply with the nominal voltage.
- The external supply circuit of the air conditioner must have a ground wire, and the power supply ground wire of the indoor unit must be connected with the external ground wire firmly.
- The wiring must be performed by professional technicians according to the circuit diagram labels.
- Distribute the wires according to the relevant electric technical standards promulgated by the State, and set the Residual Current-operated Circuit Breaker (RCCB) properly.
- The power wire and the signal wire shall be laid out neatly and properly, without mutual interference or contacting the connection pipe or valve.
- No power cable is attached to this equipment. The user can select the power cable by reference to the stipulated power supply specifications. No joint of wires is allowed.
- Upon completion of wire connection, double check it and then connect the power supply.
- An all-pole disconnection device which has at least 3mm separation distance in all pole and a residual current device(RCD) with the rating of above 10mA shall be incorporated in the fixed wiring according to the national rule.
- The appliance shall be installed in accordance with national wiring regulations.

### Specifications of power supply

Table.8-1

	Indoor unit	Outdoor unit
Model	15 Tons.	7.5 Tons.
Type	—————	
Power	208-230V 3N~ 60Hz	
Switch capacity of the main power supply/fuse(A)	20/12	90/70
Indoor unit power cable(mm <sup>2</sup> ) includes grounded wire	RVV-300/500 3×2.5 mm <sup>2</sup>	—————
Outdoor unit power cable(mm <sup>2</sup> ) includes grounded wire	—————	YCW-450/750 5X16mm <sup>2</sup>
connective wire of indoor/outside unit	RVV-300/500 2×1.0 mm <sup>2</sup> (COOL ONLY)	
Wire controls connective wire	RVVP-300/300 5×0.5 mm <sup>2</sup>	
Outdoor-outdoor unit COM wire	RVVP-300/300 3X0.5mm <sup>2</sup> (Shield wire)	

Table.8-2

	Indoor unit	Outdoor unit
Model	20 Tons.	10 Tons.
Type	Mid. static pressure	—————
Power	208-230V~ 60Hz	208-230V 3N~ 60Hz
Switch capacity of the main power supply/fuse(A)	40/20	100/70
Indoor unit power cable(mm <sup>2</sup> ) includes grounded wire	RVV-300/500 3×2.5 mm <sup>2</sup>	—————
Outdoor unit power cable(mm <sup>2</sup> ) includes grounded wire	—————	YCW-450/750 5X20mm <sup>2</sup>
connective wire of indoor/outside unit	RVV-300/500 2×1.0 mm <sup>2</sup> (COOL ONLY)	
Wire controls connective wire	RVVP-300/300 5×0.5 mm <sup>2</sup>	
Outdoor-outdoor unit COM wire	RVVP-300/300 3X0.5mm <sup>2</sup> (Shield wire)	

**NOTE**

- Please regard the refrigerant pipe system, indoor-outdoor unit connect to control wire as a integral system.
- In case installing the power supply wire and control wire are in parallel site, please insert these wires in which tubes individually and keep adequate spacing between them.
- Please refer to Page 11 for size and quantity of wire

Table.8-4

	Outdoor unit
Capacity(Btu/h)	7.5 Tons.
Power	208-230V 3N~ 60Hz
Switch capacity of the main power supply/fuse(A)	70/50
Size of power supply cable (mm <sup>2</sup> )	YCW-450/750 4×10.0 mm <sup>2</sup>
Size of power ground wire (mm <sup>2</sup> )	YCW-450/750 10.0 mm <sup>2</sup>
connective wire of indoor/outdoor unit	RVV-300/500 2×1.0 mm <sup>2</sup> (COOL ONLY)

- Power supply wire  
The specification of power supply wire as follows:  
<Power supply wire of outdoor unit>  
In case the power cable is individually provides (no power supply device is in use)

- The wire size in the table and the continuous wire length are applicable to the circumstance where the potential fall amplitude is within 2%.

- Where the continuous wire length exceeds the values in the table, select the wire size according to the relevant rules.

**Power wires**

The power wires are as follows: (schematic diagram)

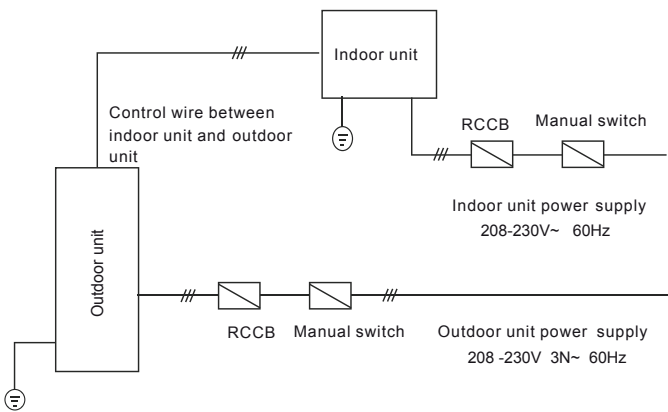

Fig. 8-1

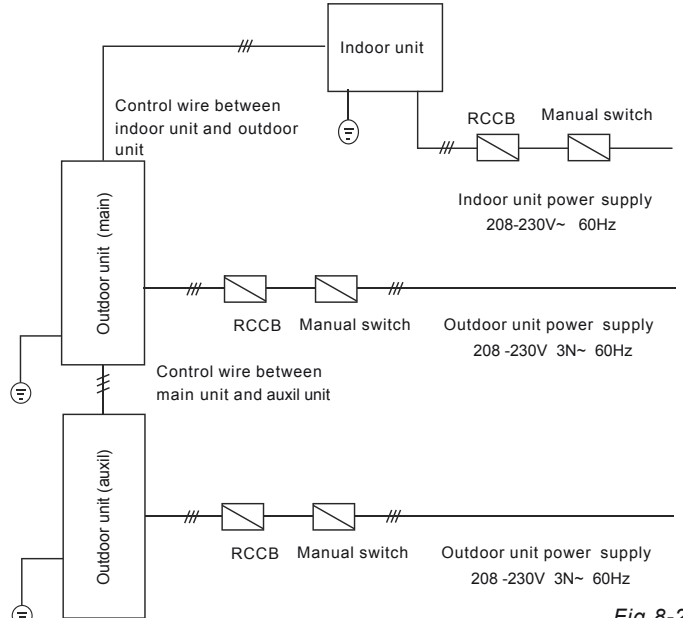

Fig. 8-2

- Set the main and auxil units  
Indoor Unit 15 and 20 Tons.

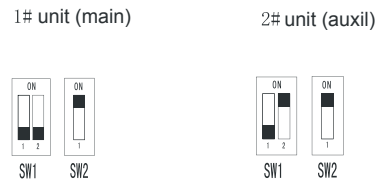

Fig. 8-3



**NOTE**

Please identify outdoor main unit and auxiliary unit. Only main unit connects with signal wire of indoor unit. Users should adjust the dial on electric control board of outdoor unit as follows, otherwise incorrect adjustment may cause malfunction.

- com connection between main and auxil units

Signal wire of indoor unit connects to outdoor main unit only and the control command to outdoor auxil unit is sent by COM wire connecting with main unit. Make sure to connect COM wire correctly, otherwise COM error may occur and auxil unit can not start. See following chart for connection:

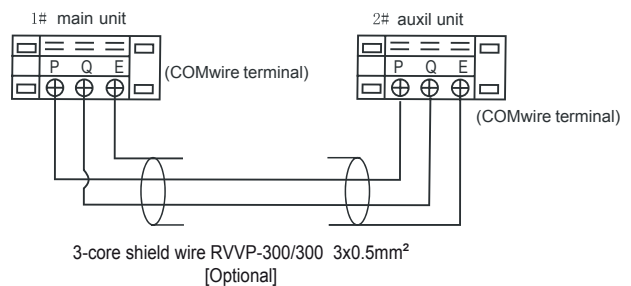

Fig. 8-4



**NOTE**

COM wire can be arranged with the connection pipe. Please take some protection measure to prevent the wire from aging.

# 9. ELECTRIC WIRE DIAGRAM

Indoor Unit 15 y 20 Tons.

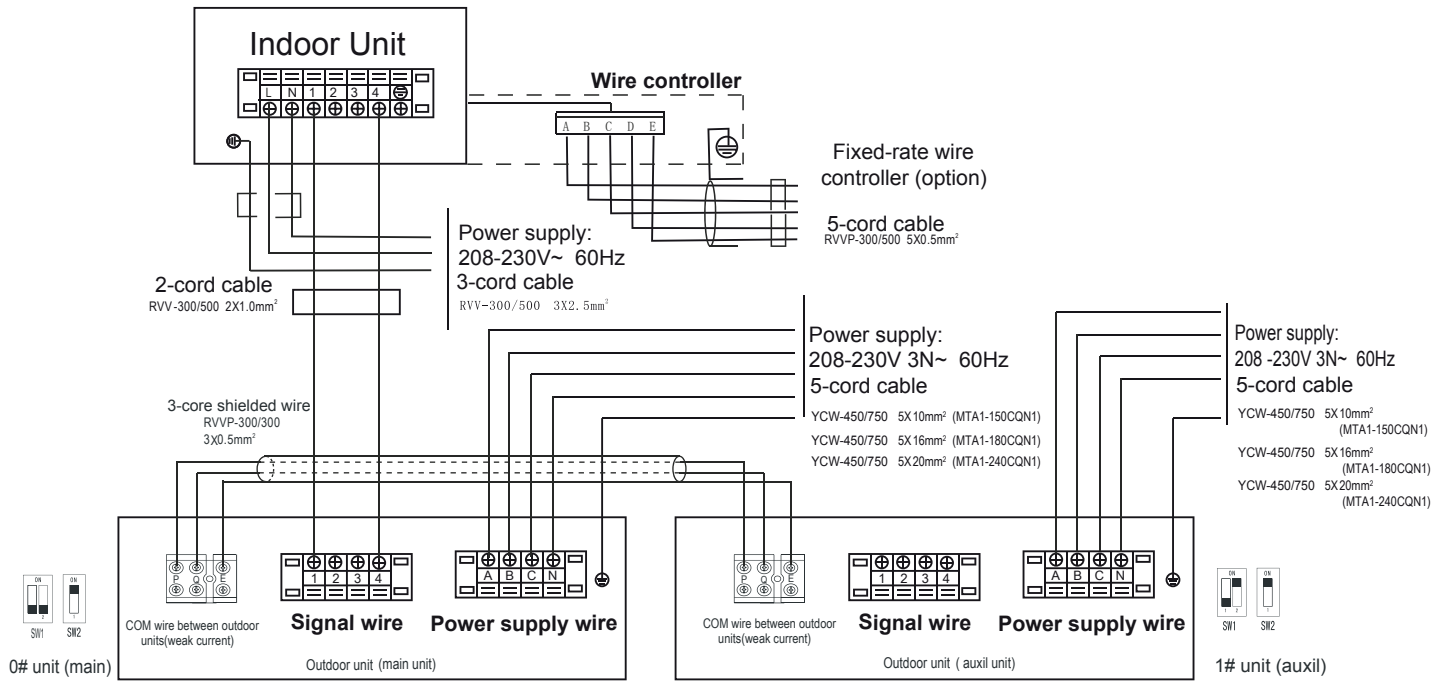

This wire diagram is applicable to cooling only model.

Fig.9-4



## NOTE

- Pay attention to the phase sequence of the power supply. If the phase sequence is reversed, the compressor will not start. Meanwhile, the fault indicator of the outdoor electric control board will light up. For details, see Outdoor unit wiring diagram on the cover plate of the electric control box .
- After shifting the phase sequence, power on the unit until the fault indicator goes out and the compressor starts up normally.

## 10. TRIAL RUN

Please conduct in accordance with "Trial Run Tenor Nameplate" on the electric control box.



### CAUTION

- Perform the trial run only after the outdoor unit has been powered on for over 12 hours.
- Check that all valves are opened before trial run.
- Check the electric safety before trial run.
- Do not perform compulsory operation in any way.(It is very dangerous if the protection device is not active)

- Perform trial run only after all installations are finished.
- Confirm the following issues before trial operation, and ✓ the box for the confirmed items.

- Check whether the indoor unit and the outdoor are installed properly.
- Check whether the piping and wiring are correct.
- Check whether the refrigerant pipeline system is inspected for leakage.
- Check whether the drain is smooth.
- Check whether the heat insulation is perfect.
- Check whether the ground cables are connected correctly.
- Check whether the pipe length and the refrigerant amount are recorded.
- Check whether the supply voltage is equal to the rated voltage of the air conditioner.
- Check whether any obstacles exist at the air inlet/outlet of the indoor or outdoor unit.
- Open the gas valve and the liquid valve.
- Connect the power supply to preheat the air conditioner.

- Install the remote controller holder as required by the user. The holder must be installed in a location suitable for transmitting the signals of the remote controller to the indoor unit.

- Trial run  
Use the remote controller or wire controller (matched) to let the air conditioner run in the cooling mode. Inspect the following items against the operation manual. (If any fault occurs, remove the fault by reference to the Section headed "Faults of Air Conditioner and Causes" in the Operation Manual.)

- Indoor unit
  - Check whether the switch of the remote controller or wire controller is normal.
  - Check whether the functional keys of the remote controller or wire controller are normal.
  - Check whether the indoor temperature conditioning is normal.
  - Check whether the indicators illuminate normally.
  - Check whether the manual operation buttons are normal.
  - Check whether the drain function is normal.
  - Check whether the connective copper pipes and the drain pipes generate condensate due to loose wrapping.
  - Open the air inlet grille to check whether any penetration or leak of water occurs, especially at the drain stopper.
  - Check whether any vibration or abnormal sound occurs during the operation.

- Outdoor unit
  - Check whether any vibration or abnormal sound occurs during the operation.
  - Check whether the air, noise and condensate generated by the unit affect the neighbors.
  - Check whether any refrigerant is leaked.