



INTENSITY®

Refresh your life



MEDIUM STATIC PRESSURE FAN & COIL

MDV-D22T2/VN1X-BA5, MDV-D28T2/VN1X-BA5, MDV-D36T2/VN1X-BA5,
MDV-D45T2/VN1X-BA5, MDV-D56T2/VN1X-BA5, MDV-D71T2/VN1X-BA5,
MDV-D80T2/VN1X-BA5, MDV-D90T2/VN1X-BA5, MDV-D112T2/VN1X-BA5,
MDV-D140T2/VN1X-BA5.

INSTALLATION MANUAL



intensity.mx



MAN-I-MSDT-0715

PRECAUTIONS.....	1
INSTALLATION INFORMATION.....	2
ACCESSORIES.....	3
INSPECTING AND HANDLING THE UNIT.....	3
INDOOR UNIT INSTALLATION	3
INSTALL THE CONNECTING PIPE.....	8
REFRIGERANT PIPE CONNECTION.....	9
CONNECT THE DRAIN PIPE.....	10
MOTOR AND DRAIN PUMP MAINTENANCE.....	12
WIRING.....	12
CONTROL OPERATION.....	13
ERROR CODE & INDICATION.....	15
TEST OPERATION.....	15

1. PRECAUTIONS

Precautions before reading the Installation manual.

- This Installation manual is for the indoor unit.
- Refer to the indoor unit Installation manual for indoor parts installation.
- Please read the power source unit Installation manual to install the power source unit.
- Please refer to the refrigerant distributor Installation manual to install the refrigerant distributor.

The safety precautions listed here are divided into two categories. In either case, important safety information is listed which must be read carefully.



WARNING

Failure to observe a warning may result in death.



CAUTION

Failure to observe a caution may result in injury or damage to the equipment.

After completing the installation, make sure that the unit operates properly during the start-up operation. Please instruct the customer on how to operate the unit and keep it maintained. Also, inform customers that they should store this Installation manual along with the owner's manual for future reference.



WARNING

- **Be sure only trained and qualified service personnel to install, repair or service the equipment.**
Improper installation, repair, and maintenance may result in electric shocks, short-circuit, leaks, fire or other damage to the equipment.
- **Install according to this installation instructions strictly.**
If installation is defective, it will cause water leakage, electrical shock fire.

- **When installing the unit in a small room, take measures against to keep refrigerant concentration from exceeding allowable safety limits in the event of refrigerant leakage.**
Contact the place of purchase for more information. Excessive refrigerant in a closed ambient can lead to oxygen deficiency.
- **Use the attached accessories parts and specified parts for installation.**
Otherwise, it will cause the set to fall, water leakage, electrical shock fire.
- **Install at a strong and firm location which is able to withstand the set's weight.**
If the strength is not enough or installation is not properly done, the set will drop to cause injury.
- **The appliance must be installed 2.5m above floor.**
- **The appliance shall not be installed in the laundry.**
- **Before obtaining access to terminals, all supply circuits must be disconnected.**
- **The appliance must be positioned so that the plug is accessible.**
- **The enclosure of the appliance shall be marked by word, or by symbols, with the direction of the fluid flow.**
- **For electrical work, follow the local national wiring standard, regulation and this installation instructions. An independent circuit and single outlet must be used.**
If electrical circuit capacity is not enough or defect in electrical work, it will cause electrical shock fire.
- **Use the specified cable and connect tightly and clamp the cable so that no external force will be acted on the terminal.**
If connection or fixing is not perfect, it will cause heat-up or fire at the connection.
- **Wiring routing must be properly arranged so that control board cover is fixed properly.**
If control board cover is not fixed perfectly, it will cause heat-up at connection point of terminal, fire or electrical shock.
- **If the supply cord is damaged, it must be replaced by the manufacture or its service agent or similarly qualified person in order to avoid a hazard.**
- **An all-pole disconnection switch having a contact separation of at least 3mm in a poles should be connected in fixed wiring.**
- **When carrying out piping connection, take care not to let air substances go into refrigeration cycle.**
Otherwise, it will cause lower capacity, abnormal high pressure in the refrigeration cycle, explosion and injury.
- **Do not modify the length of the power supply cord or use of extension cord, and do not share the single outlet with other electrical appliances.**
Otherwise, it will cause fire or electrical shock.
- **Carry out the specified installation work after taking into account strong winds, typhoons or earthquakes.**
Improper installation work may result in the equipment falling and causing accidents.

If the refrigerant leaks during installation, ventilate the area immediately.

Toxic gas may be produced if the refrigerant comes into the place contacting with fire.

The temperature of refrigerant circuit will be high, please keep the interconnection cable away from the copper tube.

After completing the installation work, check that the refrigerant does not leak.

Toxic gas may be produced if the refrigerant leaks into the room and comes into contact with a source of fire, such as a fan heater, stove or cooker.



CAUTION

Ground the air conditioner.

Do not connect the ground wire to gas or water pipes, lightning rod or a telephone ground wire. Incomplete grounding may result in electric shocks.

Be sure to install an earth leakage breaker.

Failure to install an earth leakage breaker may result in electric shocks.

Connect the outdoor unit wires , then connect the indoor unit wires.

You are not allowed to connect the air conditioner with the power source until wiring and piping the air conditioner is done.

While following the instructions in this installation manual, install drain piping in order to ensure proper drainage and insulate piping in order to prevent condensation.

Improper drain piping may result in water leakage and property damage.

Install the indoor and outdoor units, power supply wiring and connecting wires at least 1 meter away from televisions or radios in order to prevent image interference or noise.

Depending on the radio waves, a distance of 1 meter may not be sufficient enough to eliminate the noise.

The appliance is not intended for use by young children or infirm persons without supervision.

Don't install the air conditioner in the following locations:

- There is petrolatum existing.
- There is salty air surrounding (near the coast).
- There is caustic gas (the sulfide, for example) existing in the air (near a hot spring).
- The Volt vibrates violently (in the factories).
- In buses or cabinets.
- In kitchen where it is full of oil gas.
- There is strong electromagnetic wave existing.
- There are inflammable materials or gas.
- There is acid or alkaline liquid evaporating.
- Other special conditions.

2. INSTALLATION INFORMATION







- To install properly, please read this "installation manual" at first.
 - The air conditioner must be installed by qualified persons.
 - When installing the indoor unit or its tubing, please follow this manual as strictly as possible.
 - If the air conditioner is installed on a metal part of the building, it must be electrically insulated according to the relevant standards to electrical appliances.
 - When all the installation work is finished, please turn on the power only after a thorough check.
 - Regret for no further announcement if there is any change of this manual caused by product improvement.
-

INSTALLATION ORDER

- Select the location;
- Install the indoor unit;
- Install the outdoor unit;
- Install the connecting pipe ;
- Connect the drain pipe;
- Wiring;
- Test operation.

3. ACCESSORIES

Table.3-1

Name of Accessories	Q'ty	Outline	Usage
Installation manual	1	(This manual)	_____
Wire controller	1		Wire control the air-conditioner
Pipe insulation material	2		Heat insulation
Adhesive tape for seal	1		To connect drain pipe
Water outlet joint	1		For drainage
Clasp	1		Chucking the joint which connect the drain hose and the outlet of indoor unit
Network matching wire	1		The indoor unit which at the terminal of communication system should connect a impedance between port P and port Q

- Cautions on wire controller installation
 - Never throw or beat the controller.
 - Before installation, operate the wire controller to determine its location in a reception range.
 - Keep the wire controller at least 1m apart from the nearest TV set or stereo equipment. (It is necessary to prevent image disturbances or noise interferences.)
 - Do not install the wire controller in a place exposed to direct sunlight or close to a heating source, such as a stove. Note that the positive and negative poles are in right positions when loading batteries.

4. INSPECTING AND HANDLING THE UNIT

At delivery, the package should be checked and any damage should be reported immediately to the service agent.

When handling the unit, take into account the following:

- 1  Fragile, handle the unit with care.
- 2 Choose on before hand the path along which the unit is to be brought in.
- 3 Move this unit as originally package as possible.
- 4 When lifting the unit, always use protectors to prevent belt damage and pay attention to the position of the unit's centre of gravity.

5. INDOOR UNIT INSTALLATION

Confirm that there is enough room for installation and maintenance.

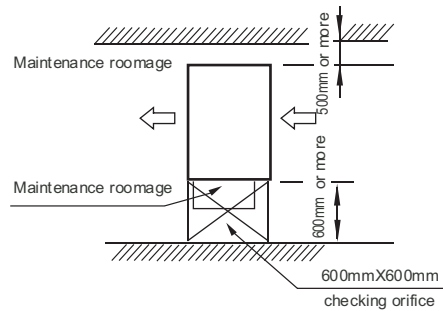

Fig.5-1

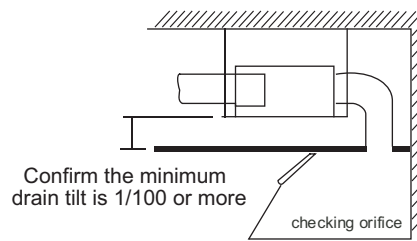

Fig.5-2

5.1 Installation Φ10 Hanging Screw Bolts (4 Bolts)

- Please refer to the following figure for the distance measurement between the screw bolts.
- Please install with Φ10 hanging screw bolts.
- The handling to the ceiling varies from the constructions, consult the construction personnels for the specific procedures.
 - The size of the ceiling to be handled ... do keep the ceiling flat. Consolidate the roof beam for possible vibration.
 - Cut off the roof beam.
 - Strengthen the place cut off, and consolidate the roof beam.
- Carry out the pipe and line operation in the ceiling after finishing the installation of the main body. While choosing where to start the operation, determine the direction of the pipes to be drawn out. Especially in case there is a ceiling, position the refrigerant pipes, drain pipes, indoor & outdoor lines to the connection places before hanging up the machine.
- The installation of hanging screw bolts.

5.2 Wooden construction

Put the square timber transversely over the roof beam, then install the hanging screw bolts. (Refer to Fig.5-3)

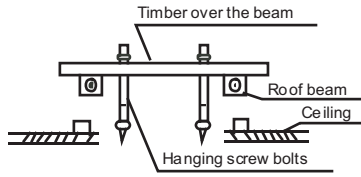

Fig.5-3

5.3 New concrete bricks

Inlaying or embedding the screw bolts (refer to Fig.5-4)

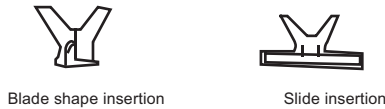

Fig.5-4

5.4 For original concrete bricks

Use embedding screw bolt, crock and stick harness (refer to Fig.5-5)

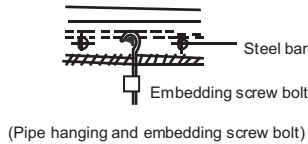

Fig.5-5

5.5 Steel roof beam structure

Install and use directly the supporting angle steel. (refer to Fig.5-6)

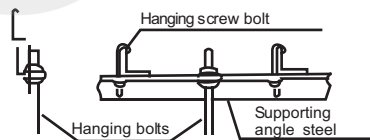

Fig.5-6

5.6 Overhanging the indoor unit

- (1) Overhang the indoor unit onto the hanging screw bolts with block.
- (2) Position the indoor unit in a flat level by using the level indicator, unless it may cause leakage.

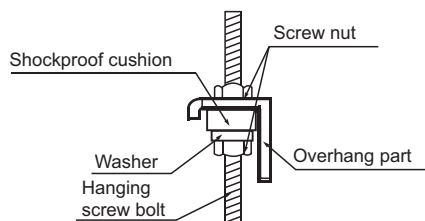

Fig.5-7

5.7 Diagrammatic sketch for Installing the main body

Installing the dust proof net and canvas air passage

- (1) Install the dust proof net according to the installation manual;
- (2) Install the canvas air passage underneath the dust proof net.

5.8 Duct Design

- (1) Air inlet and air outlet duct should be apart far enough to prevent air outlet entering Air Inlet.
- (2) There is dust filter on the indoor unit.

- Recommended duct connection

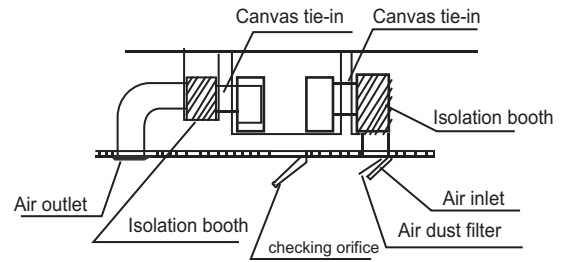

Fig.5-8



NOTE

1. Do not put the connecting duct weight on the indoor unit.
2. When connecting duct, use inflammable canvas tie-in to prevent vibrating.
3. When connecting duct, install in place prone to takedown for maintenance.
4. Change the fan motor static pressure corresponding to external duct static pressure.
5. If installed in place like meeting room where noise is easy to be perceived, design isolation booth and internal duct underlayer to muffle the duct system and weaken the air encounter noise in the duct.

■ The positioning of ceiling hole and indoor unit and hanging screw bolts

routine method of installation: the size of installation for indoor unit following the Fig.5-9 and the Table 5-1

Outline dimension and air outlet opening size

Unit: mm

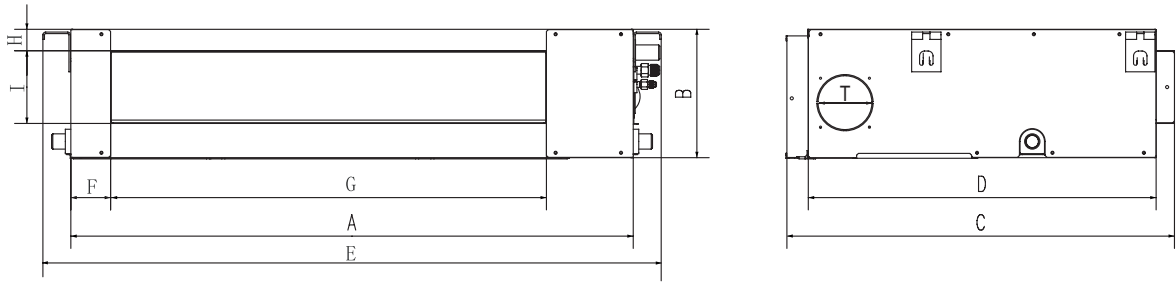

Air return opening size

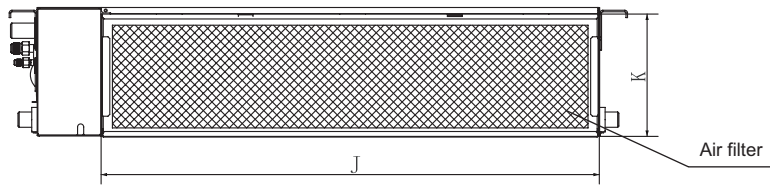

Position size of descensional ventilation opening

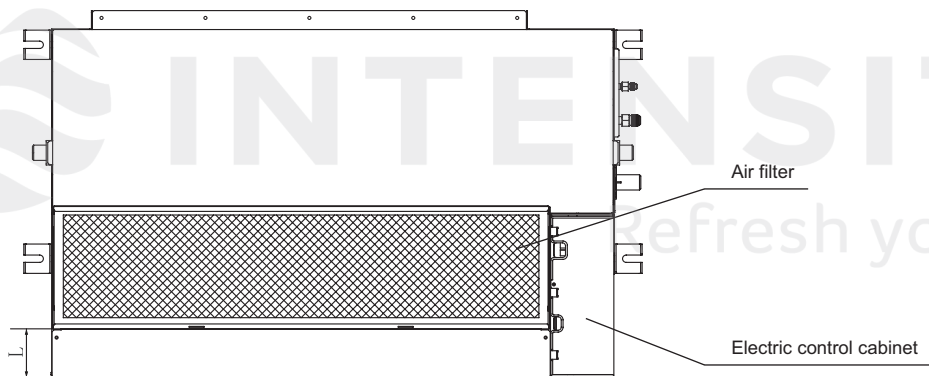

Size of mounted lug

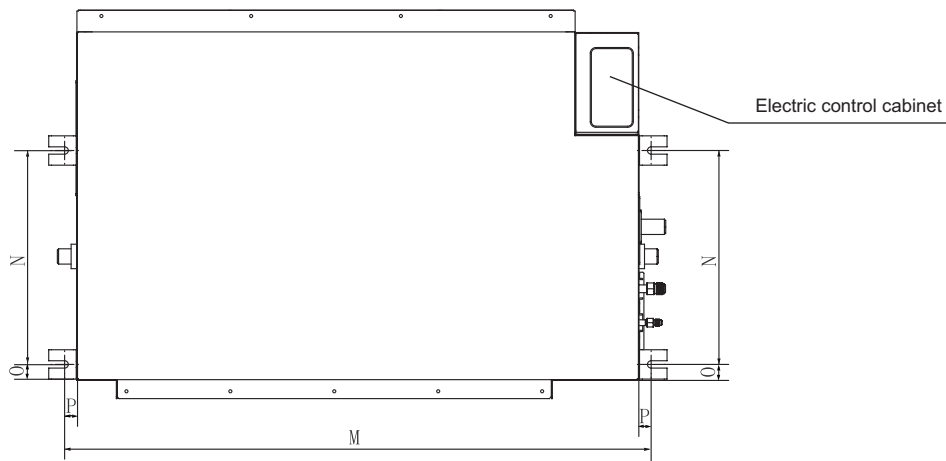

Fig.5-9

Table.5-1

	Outline dimension					air outlet opening size					air return opening size				Size of mounted lug				New air inlet
	A	B	C	D	E	F	G	H	I	J	K	L	M	N	O	P	T		
22~36	700	210	635	570	790	65	493	35	119	595	200	80	740	350	26	20	Φ92		
45~56	920	210	635	570	1010	65	713	35	119	815	200	80	960	350	26	20	Φ92		
71	920	270	635	570	1010	65	713	35	179	815	260	20	960	350	26	20	Φ92		
71(New)	1140	210	635	570	1230	65	933	35	119	1035	200	75	1180	350	26	20	Φ92		
80~112	1140	270	775	710	1230	65	933	35	179	1035	260	20	1180	490	26	20	Φ125		
140	1200	300	865	800	1290	80	993	40	204	1094	288	45	1240	500	26	20	Φ125		

Table.5-2

Pipe Material		Copper Pipe for Air Conditioner			Refrigerant
Mode		2200~4500	5600~9000	10000~14000	
Size(mm)	F(Liquid side)	Φ6.4	Φ9.5	Φ9.5	R410A
	G(Gas side)	Φ12.7	Φ15.9	Φ15.9	

■ How to adjust the air ventilated direction? (From rear ventilated adjust it to descensional.)

1. Take off ventilation panel and flange, cut off the staples at side rail.

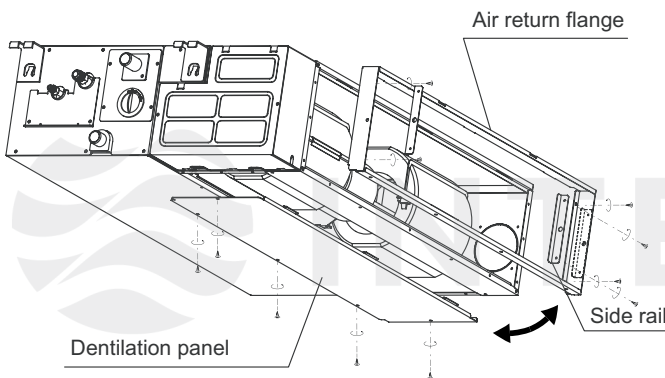

2. Stick the attached seal sponge as per the indicating place in the following fig, and then change the mounting positions of air return panel and air return flange .

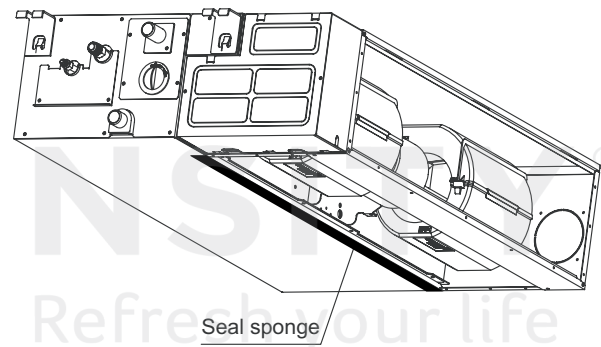

3. When install the filter mesh, please plug it into flange inclined from air return opening, and then push up.

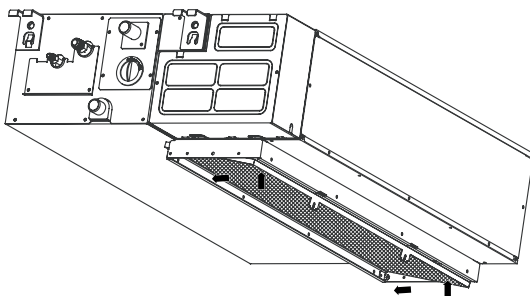

4. The installation has finish, upon filter mesh which fixing blocks have been insert to the flange positional holes.

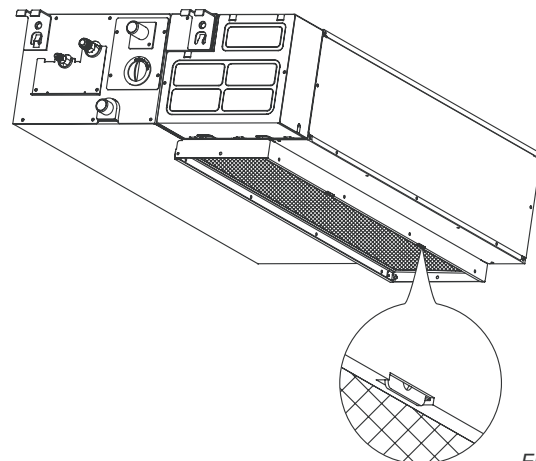

Fig.5-10



NOTE

All the pictures in this manual are for explanation purpose only. They may be slightly different from the air conditioner you purchased (depend on model).The actual shape shall prevail.

5.9 Fan performances

Static pressure curve

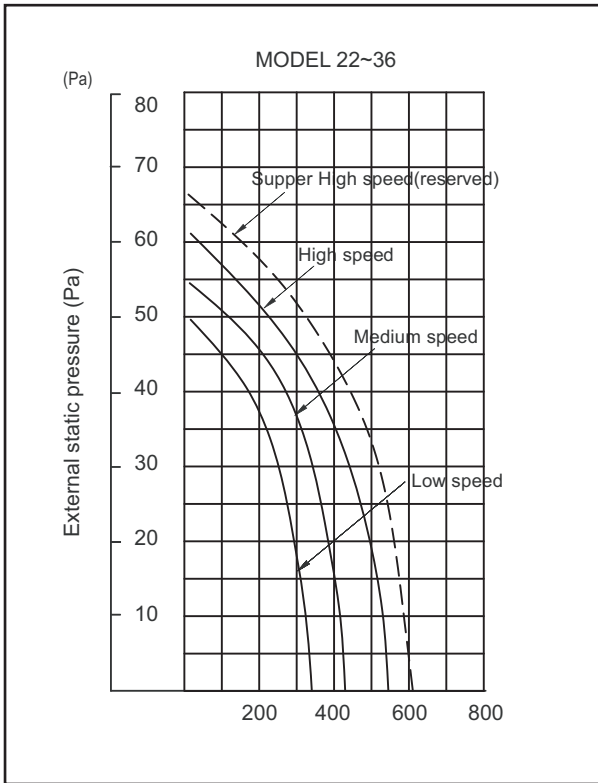

Fig.5-11

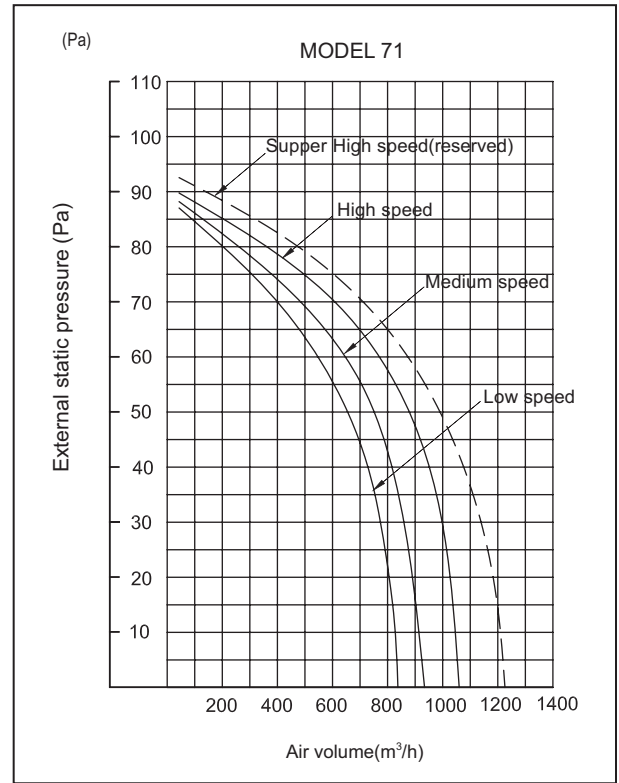

Fig.5-13

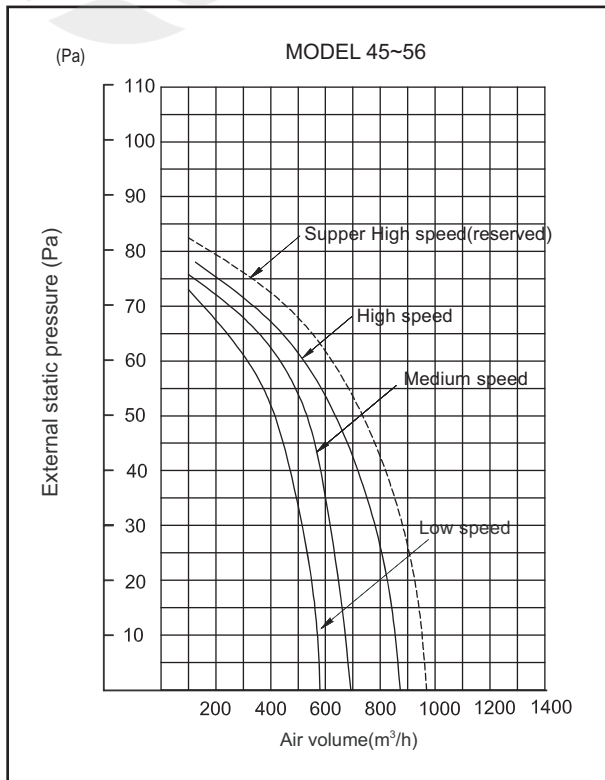

Fig.5-12

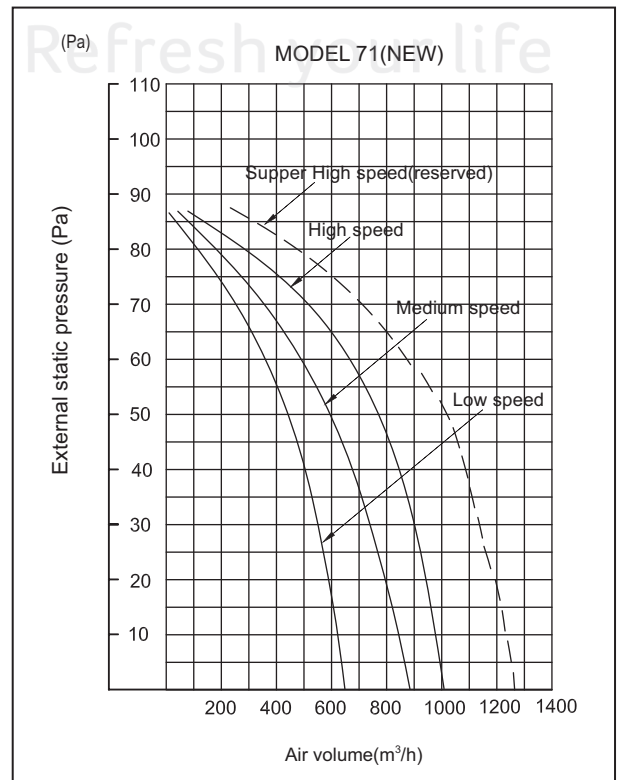

Fig.5-14

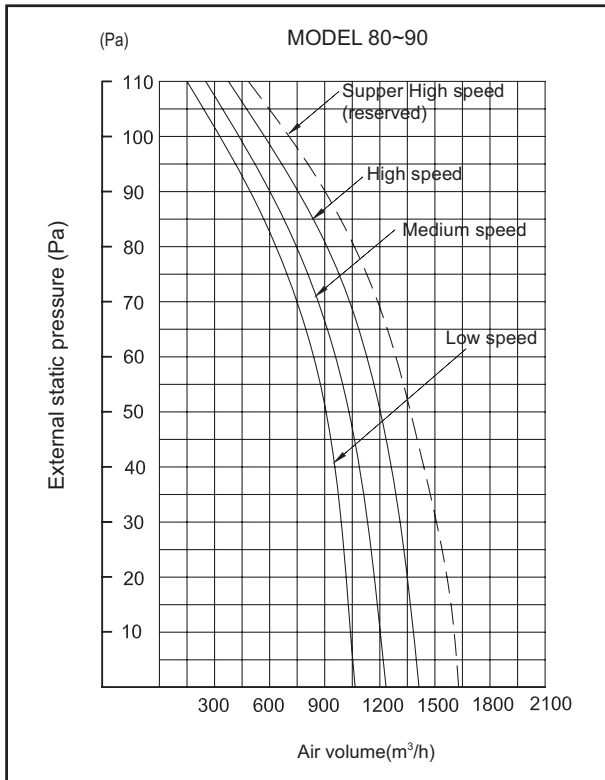

Fig.5-15

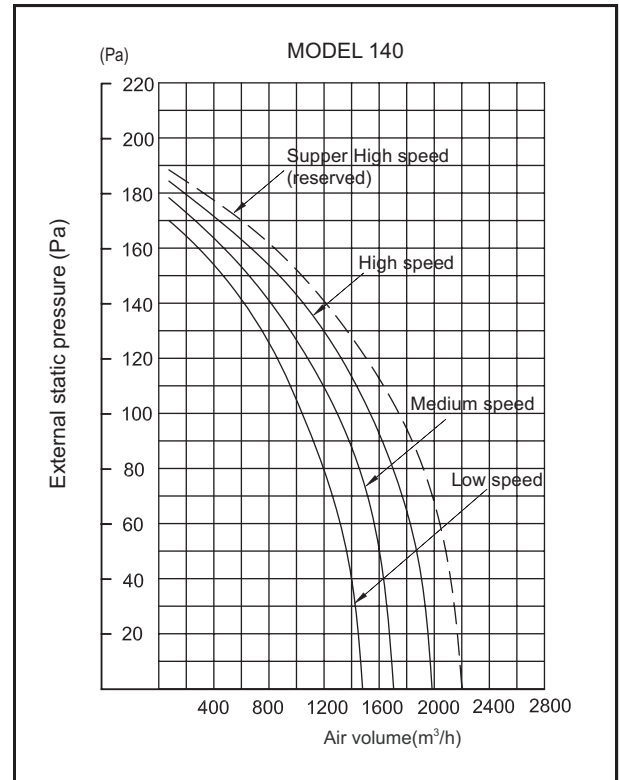

Fig.5-17

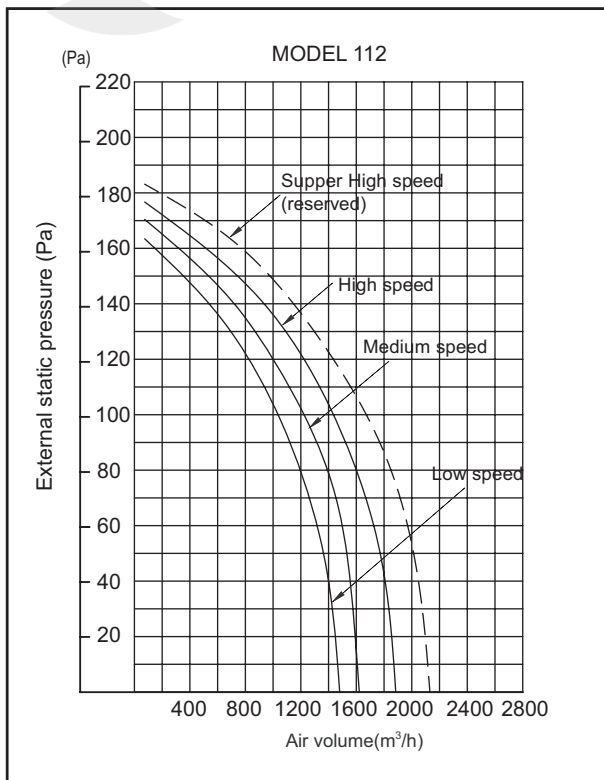

Fig.5-16

6. INSTALL THE CONNECTING PIPE

- Check whether the height drop between the indoor unit and outdoor unit, the length of refrigerant pipe, and the number of the bends meet the following requirements:
 - The max height drop and The length of refrigerant pipe depending on the outdoor unit. (If the height drop is more than 10m, you had better put the outdoor unit over above the indoor unit.)
 - The number bends fewer than 15
 - Do not let air, dust, or other impurities fall in the pipe system during the time of installation.
 - The connecting pipe should not be installed until the indoor and outdoor units have been fixed already.
 - Keep the connecting pipe dry, and do not let moisture in during installation.
 - The Procedure of Connecting Pipes

Measure the necessary length of the connecting pipe, and make it by the following way.

 - Connect the indoor unit at first, then the outdoor unit.
- ① Bend the tubing in proper way. Dont harm them.
 - ② Daub the surfaces of the flare pipe and the joint nuts with frozen oil, and wrench it for 3~4rounds with hands before fasten the flare nuts. (Refer to Fig.6-1)
 - ③ Be sure to use two wrenches simultaneously when you connect or disconnect the pipes.

- The stop valve of the outdoor unit should be closed absolutely (as original state). Every time you connect it, first loosen the nuts at the part of stop valve, then connect the flare pipe immediately (in 5 minutes). If the nuts have been loosened for a long time, dusts and other impurities may enter the pipe system and may cause malfunction later. So please expel the air out of the pipe with refrigerant before connection.
- Expel the air (refer to the "Expel The Air") after connecting the refrigerant pipe with the indoor unit and the outdoor unit. Then fasten the nuts at the repair-points.
- Notices For Bendable pipe.
 - The bending angle should not exceed 90°C
 - Bending position is preferably in the bendable pipe. The larger the better it is .
 - Do not bend the pipe more than three times.
- Bend the connecting pipe of small wall thickness.
 - Cut out a desired concave at the bending part of the insulating pipe.
 - Then expose the pipe (cover it with tapes after bending).
 - To prevent collapsing or deforming, please bend the pipe at its biggest radius.
 - Use bender to get a small radius pipes.
- Use the market brass pipe.
 - Be sure to use the same insulating materials when you buy the brass pipe. (More than 9mm thick).

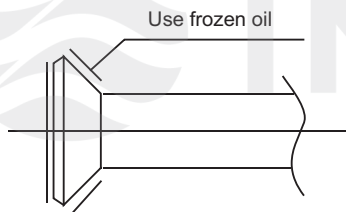

Fig.6-1

Bend the pipe with thumb



Fig.6-2

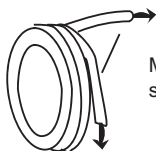

Fig.6-3

- Locate The Pipe
 - Drill a hole in the wall (suitable just for the size of the wall conduit, 90mm in general), then set on the fittings such as the wall conduit and its cover.
 - Bind the connecting pipe and the cables together tightly with binding tapes. Do not let air in, which will cause water leakage by condensation.
 - Pass the bound connecting pipe through the wall conduit from outside. Be careful of the pipe all ocation to do no damage to the tubing.
- Connect the pipes.

- Then, open the stem of stop valves of the outdoor unit to make the refrigerant pipe connecting the indoor unit with the outdoor unit fluently flow.
- Be sure of no leakage by checking it with leak detector or soap water.
- Cover the joint of the connecting pipe to the indoor unit with the sound proof/insulating sheath (fittings), and bind it well with the tapes to prevent leakage.

7. REFRIGERANT PIPE CONNECTION

7.1 Expel The Air

- Flaring
 - Cut a pipe with a pipe cutter.
 - Insert a flare nut into a pipe and flare the pipe.

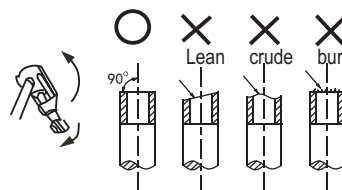

Fig.7-1

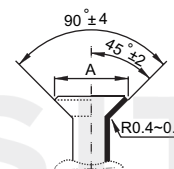

Fig.7-2

Table.7-1

Outside diameter	A(mm)	
	Max	Min
Φ6.4mm	8.7	8.3
Φ9.5mm	12.4	12.0
Φ12.7mm	15.8	15.4
Φ15.9mm	19.0	18.6
Φ19.1mm	23.3	22.9

- Fasten the nut
 - Put the connecting tubing at the proper position, wrench the nuts with hands then fasten it with a wrench. (Refer to Fig.7-3)
 - Too large torque will harm the bellmouthing and too small will cause leakage. Please determine the torque according to Table.7-2.

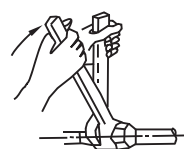

Fig.7-3

Table.7-2

Tubing size	Torque
Φ6.4mm	14.2~17.2 N.m (144~176 kgf.cm)
Φ9.5mm	32.7~39.9 N.m (333~407 kgf.cm)
Φ12.7mm	49.5~60.3 N.m (504~616 kgf.cm)
Φ15.9mm	61.8~75.4 N.m (630~770 kgf.cm)
Φ19.1mm	97.2~118.6 N.m (990~1210 kgf.cm)

- The necessary filling amount of refrigerant
 - Refrigerant volume to be added is calculated according to outdoor unit installation manual .Be sure to add refrigerant measuring by a scale. L: The length of the pipe
 - Please record the quantity added and store it carefully for future maintenance.
- Expel the air with a vacuum pump (Refer to Fig.7-4) (Please refer to its manual for the way of using manifold valve)
 - Loosen and remove the maintenance nuts of stop valves A and B, and connect the charge hose of the manifold valve with the maintenance terminator of stop valve A. (Be sure that stop valves A and B are both closed)
 - Connect the joint of the charge hose with the vacuum pump.
 - Open the Lo-lever of the manifold valve completely.
 - Turn on the vacuum pump. At the beginning of pumping, loosen the maintenance terminator nut of stop valve B a little to check whether the air comes in (the sound of the pump changes, and the indicator of compound meter turns below zero). Then fasten the nut.
 - When the pumping has finished, close the Lo-lever of the manifold valve completely and turn off the vacuum pump.
 - When you have pumped for over 15 minutes, please confirm that the indicator of multimeter is on $-1.0 \times 10^5 \text{Pa}$ (-76cmHg)
 - Loosen and remove the quadrangle cover of stop valves A and B to open stop valve A and B completely, then fasten them.
 - Disassemble the charge hose from the repair-mouth of stop valve A, and fasten the nut.

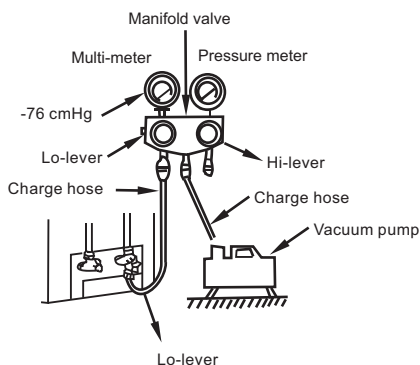

Fig.7-4

- All the stop valves should be opened before test operation. Each air conditioner has two stop valves of different sizes on the side of the outdoor unit which operate as Lo-stop valve, respectively. (Refer to Fig.7-5)

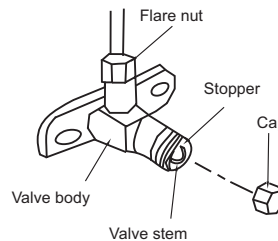
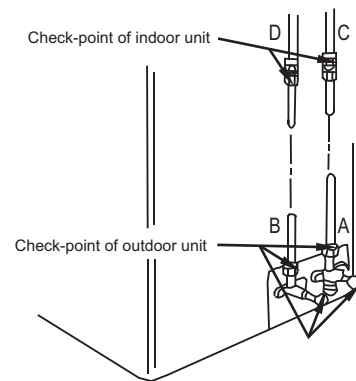

Fig.7-5

7.2 Check The Leakage

- Check all the joints with the leak detector or soap water. (See Fig.7-6 as a reference illustration)



A.....Lo-stop valve B.....Hi-stop valve
C,D...Joints of the connecting pipe to the indoor unit.

Fig.7-6

7.3 Insulation

- Be sure to with insulating materials cover all the exposed parts of the flare pipe joints and refrigerant pipe on the liquid-side and the gas-side. Ensure that there is no gap between them.
- Incomplete insulation may cause water condensation.

8. CONNECT THE DRAIN PIPE

■ Install the drainpipe of the indoor unit

- Please use the accessory drain hose to connect the outlet of indoor unit with the PVC water pipe, and then use the accessory the clasp for chucking (Refer to Fig.8-1).
- Connections of other water pipes please use rigid PVC binder, and confirm there whether have leakage or not.

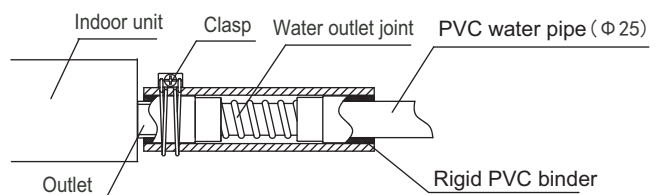

Fig.8-1

- To prevent water from flowing backwards into the air conditioner while the air conditioner stops, please lean the drainpipe down toward outdoor (outlet-side) at a degree of over 1/ 100. And please avoid any bulge or water deposit.
- Do not drag the drainpipe violently when connecting to prevent the body from being pulled. Meanwhile, one supportpoint should be set every 0.8~1.0m to prevent the drainpipe from yielding. Or you can tie the drainpipe with the connecting pipe to fix it.
- In the case of prolonged drainpipe, you had better tighten its indoor part with a protection tube to prevent it from loosening.
- In case the drainpipe outlet is higher than pumping connective pipe of the main body, the drainpipe must be arranged upwards vertically by using connective assembly of the water outlet for vertical bending, and the height of the drainpipe shall set to the defrosting pan surface no more than 600mm, otherwise, too much backflow while shutdown would leads to overflow (Refer to Fig.8-2).(Only available for the unit with pump.)
- The end of the drainpipe should be over 50mm higher than the ground or the bottom of the drainage chute, and do not immerse it in water. If you discharge the water directly into sewage, be sure to make a U-form aquaseal by bending the

The drain pipe installation for the unit with pump.

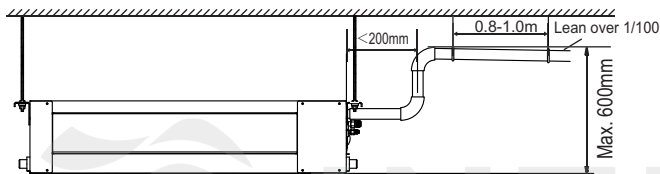

Fig. 8-2

The drain pipe installation for the unit without pump.

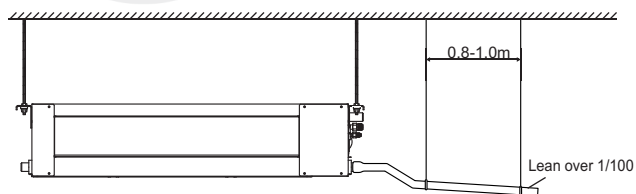

Fig. 8-3

■ Drainage test

- Check whether the drainpipe is unhindered.
- New built house should have this test done before paving the ceiling.

■ The unit with pump.

- 1 Remove the test cover (Rotate the test cover to opening up), and stow water of about 2000ml to the water receiver through the stow tube.

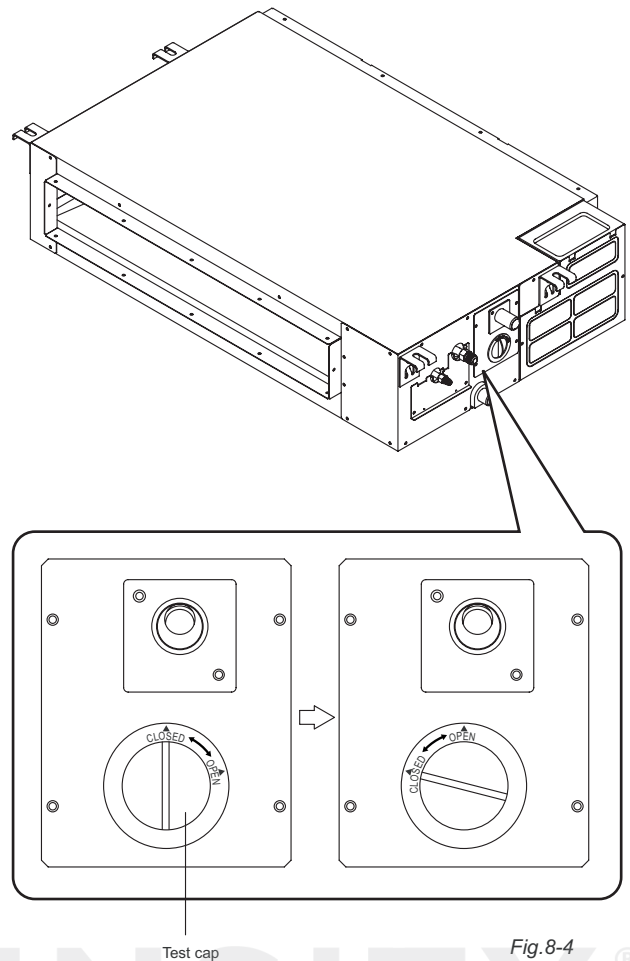

Fig. 8-4

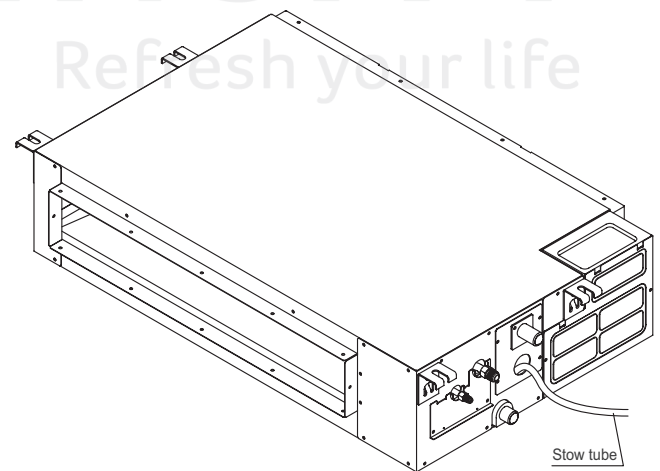

Fig. 8-5

- 2 Turn on the power, and operate the air conditioner under the "COOLING" mode. Listen to the sound of the drain pump. Check whether the water is discharged well (a lag of 1min is allowed before discharging, according to the length of the drain pipe), and check whether water leaks from the joints.
- 3 Stop the air conditioner, turn off the power, and reset the test cover to its original position.

■ The unit without pump.

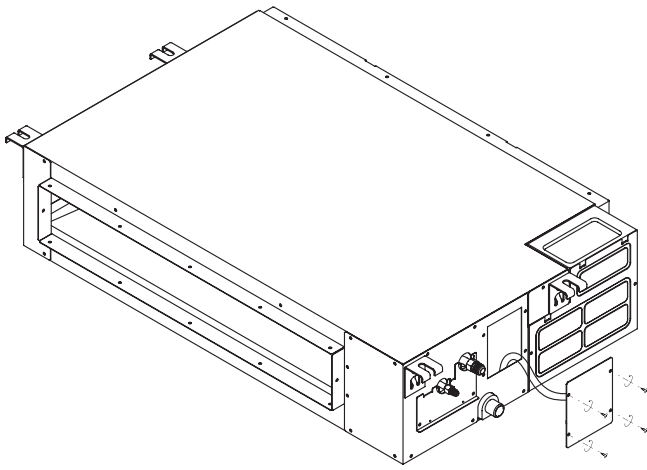

Fig.8-6

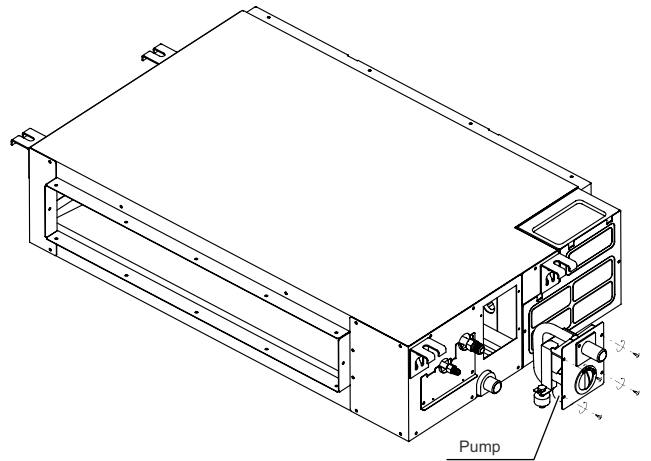

Fig.9-2

- Remove the test cover, and stow water of about 2000ml to the water receiver through the stow tube, check whether the drainpipe is unhindered.

9. MOTOR AND DRAIN PUMP MAINTENANCE

(Take rear ventilated as example)

Motor maintain:

1. Remove off the ventilated panel.
2. Remove off a half of motor housing.
3. Take off the motor.

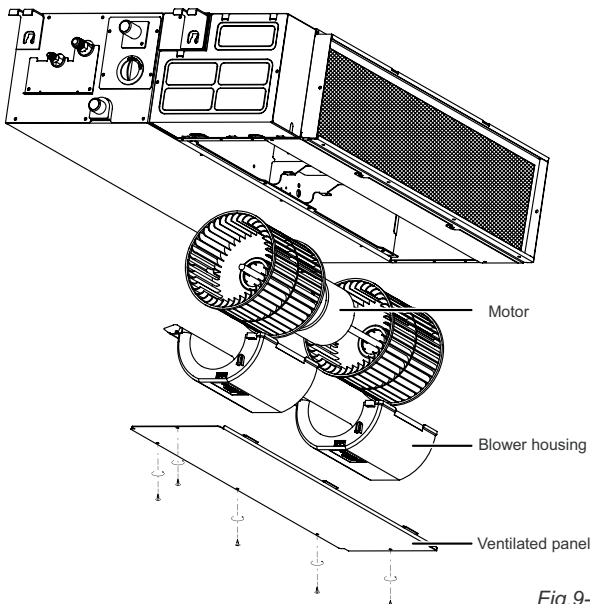

Fig.9-1

Pump maintain:

1. Screw off four screws from drain pump.
2. Plug off pump power supply and water level switch cable.
3. Take off pump.

10. WIRING

■ Attaching wiring

- The air conditioner should use separate power supply with rated voltage.
- The external power supply to the air conditioner should have ground wiring, which is linked to the ground wiring of the indoor and outdoor unit.
- The wiring work should be done by qualified persons according to circuit drawing.
- A leakage protector should be installed according to the National Standard concerning electrical appliance.
- Be sure to locate the power wiring and the signal wiring well to avoid cross-disturbance and their contact with connecting pipe or stop valve body.
- Generally, do not twist two wiring together unless the joint is soldered well and covered with insulator tape.
- Do not turn on the power until you have checked carefully after wiring.

■ The Specification of Power.

Table.10-1

Model(W)		2200~14000
Power	Phase	1-Phase
	Frequency and volt	220-240V~ 50Hz 208-230V~ 60Hz
Power switch	Capacity	15A
	Safety fuse	15A
Indoor unit power wiring (mm ²)		3×2.5
Indoor/outdoor connecting wiring (mm ²) (Electric signal)		3-core shielded wire 3×0.75



CAUTION

A disconnection device having an air gap contact separation in all active conductors should be incorporated in the fixed wiring according to the National Wiring Regulation.

■ Wiring chart

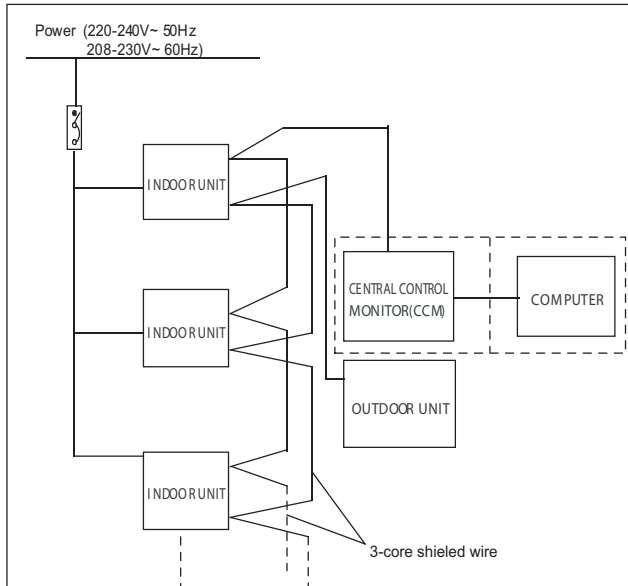

Fig.10-1



CAUTION

The reserved function is indicated in broken line table, users can select it when necessary.

■ Terminal board diagram

Please refer to the indoor unit wiring diagram for the wiring.



NOTE

The air-conditioners can connect with Central Control Monitor (CCM). Before operation, please wiring correctly and set system address and network address of indoor units.

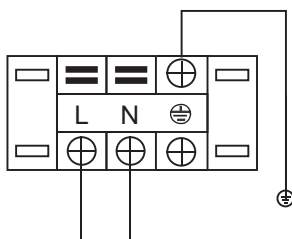

To indoor power
220-240V~ 50Hz
208-230V~ 60Hz

Fig.10-2

Please use 3-core shielded wire, and connect the shielded layer to ⊕ .

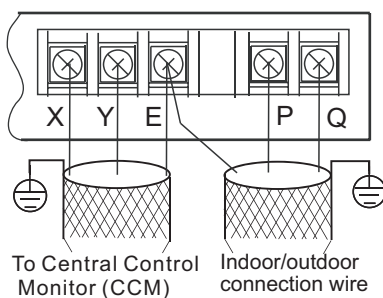

To Central Control Monitor (CCM)
Indoor/outdoor connection wire

Fig.10-3

11. CONTROL OPERATION

11.1 Horsepower set

Horsepower code

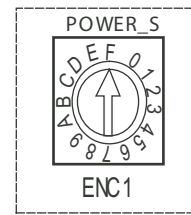

Base on different purposes to setting the switch cords on PC panel of indoor electrical control box. Once finish the setting, please cut off the main power, and then input power again, otherwise, setting function could not work.

Table.11-1

ENC1	Toggle switch	For set horsepower
	Code	Capacity(Horsepower)
	0	2200W(0.8HP)
	1	2800W(1.0HP)
	2	3600W(1.2HP)
	3	4500W(1.7HP)
	4	5600W(2.0HP)
	5	7100W(2.5HP)
	6	8000W(3.0HP)
	7	9000W(3.2HP) ®
	8	10000W(3.5HP)
		11200W(4.0HP)
	9	12500W(4.4HP)
		14000W(5.0HP)

Note: The horsepower has been set before leaving the factory, anyone can't modify it except the maintenance person.



CAUTION

The system together have 64units(0-63), everyone has only system addresscode, if two addresses are the same in one system, the abnormal operation will occur.







Please switch off the power before setting, otherwise the unexpected error will occur.

11.2 Network address set









- 1) Network address is set by communication of indoor and outdoor unit; the address is the same as indoor address, there is no need to set separately.
- 2) The central control of indoor units can be done on outdoor unit, there is no need to control indoor unit separately, for details please refer to V4+ outdoor unit manual.
- 3) For previous control of indoor units, the network can be set by connecting (X,Y,E) terminals, there is no need to set network address. The network can also be set by outer network module and main board (CN20).

11.3 Main board Code designation





SW1 definition

ON SW1  1 2 3 4	<ul style="list-style-type: none"> ● 1 means factory test mode ● 0 means add. auto searching mode (default setting) 	ON SW1  1 2 3 4	<ul style="list-style-type: none"> ● 01 means DC fan static pressure is 1 (reserved)
ON SW1  1 2 3 4	<ul style="list-style-type: none"> ● 1 means DC fan Is chosen ● 0 means AC fan Is chosen 	ON SW1  1 2 3 4	<ul style="list-style-type: none"> ● 10 means DC fan static pressure is 2 (reserved)
ON SW1  1 2 3 4	<ul style="list-style-type: none"> ● 00 means DC fan static pressure is 0 (reserved) 	ON SW1  1 2 3 4	<ul style="list-style-type: none"> ● 11 means DC fan static pressure is 3 (reserved)



SW2 definition

ON SW2  1 2 3 4	<ul style="list-style-type: none"> ● 00 means the temperature is 15 degrees when shutting down the unit for cold wind proof. 	ON SW2  1 2 3 4	<ul style="list-style-type: none"> ● 00 means the time of stopping TERMAL fan is 4 minutes
ON SW2  1 2 3 4	<ul style="list-style-type: none"> ● 01 means the temperature is 20 degrees when shutting down the unit for cold wind proof. 	ON SW2  1 2 3 4	<ul style="list-style-type: none"> ● 01 means the time of stopping TERMAL fan is 8 minutes
ON SW2  1 2 3 4	<ul style="list-style-type: none"> ● 10 means the temperature is 24 degrees when shutting down the unit for cold wind proof. 	ON SW2  1 2 3 4	<ul style="list-style-type: none"> ● 10 means the time of stopping TERMAL fan is 12 minutes
ON SW2  1 2 3 4	<ul style="list-style-type: none"> ● 11 means the temperature is 26 degrees when shutting down the unit for cold wind proof. 	ON SW2  1 2 3 4	<ul style="list-style-type: none"> ● 11 means the time of stopping TERMAL fan is 16 minutes



SW5 definition

ON SW5  1 2	<ul style="list-style-type: none"> ● 00 means temperature compensation is 6 degrees under heating mode 	ON SW5  1 2	<ul style="list-style-type: none"> ● 10 means temperature compensation is 4 degrees under heating mode
ON SW5  1 2	<ul style="list-style-type: none"> ● 01 means temperature compensation is 2 degrees under heating mode 	ON SW5  1 2	<ul style="list-style-type: none"> ● 11 means temperature compensation is 8 degrees under heating mode

SW6 definition

ON SW6  1 2 3	<ul style="list-style-type: none"> ● 1 means old display panel ● 0 means new display panel
ON SW6  1 2 3	<ul style="list-style-type: none"> ● 1 means auto wind under auto mode ● 0 means auto wind under non auto mode
ON SW6  1 2 3	reserved

J1, J2 definition

J1 	J1 no Jumpers means power off memory function
J1 	J1 Jumpers means no power off memory function
J2 	reserved

SW7 definition

	Standard configure
	Last one in the network

0/1 definition

	Means 0
	Means 1

12. ERROR CODE & INDICATION

• No address when first time power on	Timer LED and run LED flash together or show "FE"
• M_Home non-matching	4 LED flash together or show "H0"
• mode conflict	Defrost LED flash or show "E0"
• communication error between indoor and outdoor unit	Timer LED flash or show "E1"
• temp.sensor (T1) error	Run LED flash or show "E2"
• temp.sensor(T2) error	Run LED flash or show "E3"
• temp.sensor(T2B) error	Run LED flash or show "E4"
• EEPROM error	Defrost LED flash slowly or show "E7"
• outdoor unit error	Alarm LED flash slowly or show "Ed"
• water level alarm	Alarm LED flash or show "EE"

13. TEST OPERATION

- The test operation must be carried out after the entire installation has been completed.
- Please confirm the following points before the test operation:
 - The indoor unit and outdoor unit are installed properly.
 - Tubing and wiring are correctly completed.
 - The refrigerant pipe system is leakage-checked.
 - The drainage is unimpeded.
 - The heating insulation works well.
 - The ground wiring is connected correctly.
 - The length of the tubing and the added stow capacity of the refrigerant have been recorded.
 - The power voltage fits the rated voltage of the air conditioner.
 - There is no obstacle at the outlet and inlet of the outdoor and indoor units.
 - The gas-side and liquid-side stop valves are both opened.
 - The air conditioner is pre-heated by turning on the power.
- According to the user's requirement, install the remote controller frame where the remote controller's signal can reach the indoor unit smoothly.
- Test operation
 - Set the air conditioner under the mode of "COOLING" with the remote controller, and check the following points. If there is any malfunction, please resolve it according to the chapter "Troubleshooting" in the "Owner's Manual".
 - The indoor unit
 - Whether the switch on the remote controller works well.
 - Whether the buttons on the remote controller works well.
 - Whether the air flow louver moves normally.
 - Whether the room temperature is adjusted well.
 - Whether the indicator lights normally.
 - Whether the temporary buttons works well.
 - Whether the drainage is normal.
 - Whether there is vibration or abnormal noise during operation.
 - Whether the air conditioner heats well in the case of the HEATING/COOLING type.
 - The outdoor unit
 - Whether there is vibration or abnormal noise during operation.
 - Whether the generated wind, noise, or condensed of by the air conditioner have influenced your neighborhood.
 - Whether any of the refrigerant is leaked.



CAUTION

A protection feature prevents the air conditioner from being activated for approximately 3 minutes when it is restarted immediately after shut off.

