



INTENSITY®

Refresh your life



ONE-WAY CASSETTE CHILLED WATER

IC1H-04KF-3.

INSTALLATION MANUAL



intensity.mx



MAN-I-C10AH-1015

One-way Cassette FCU

Contents

1.	Nomenclature	2
2.	Features	3
3.	Specifications.....	4
4.	Dimensions.....	5
5.	Service Spaces.....	6
6.	Wiring Diagrams	7
7.	Capacity Tables.....	10
8.	Exploded View.....	11
9.	Installation	12
10.	Troubleshooting.....	21



INTENSITY®

Refresh your life

1. Nomenclature

I C 1 H - 04 KF - 3

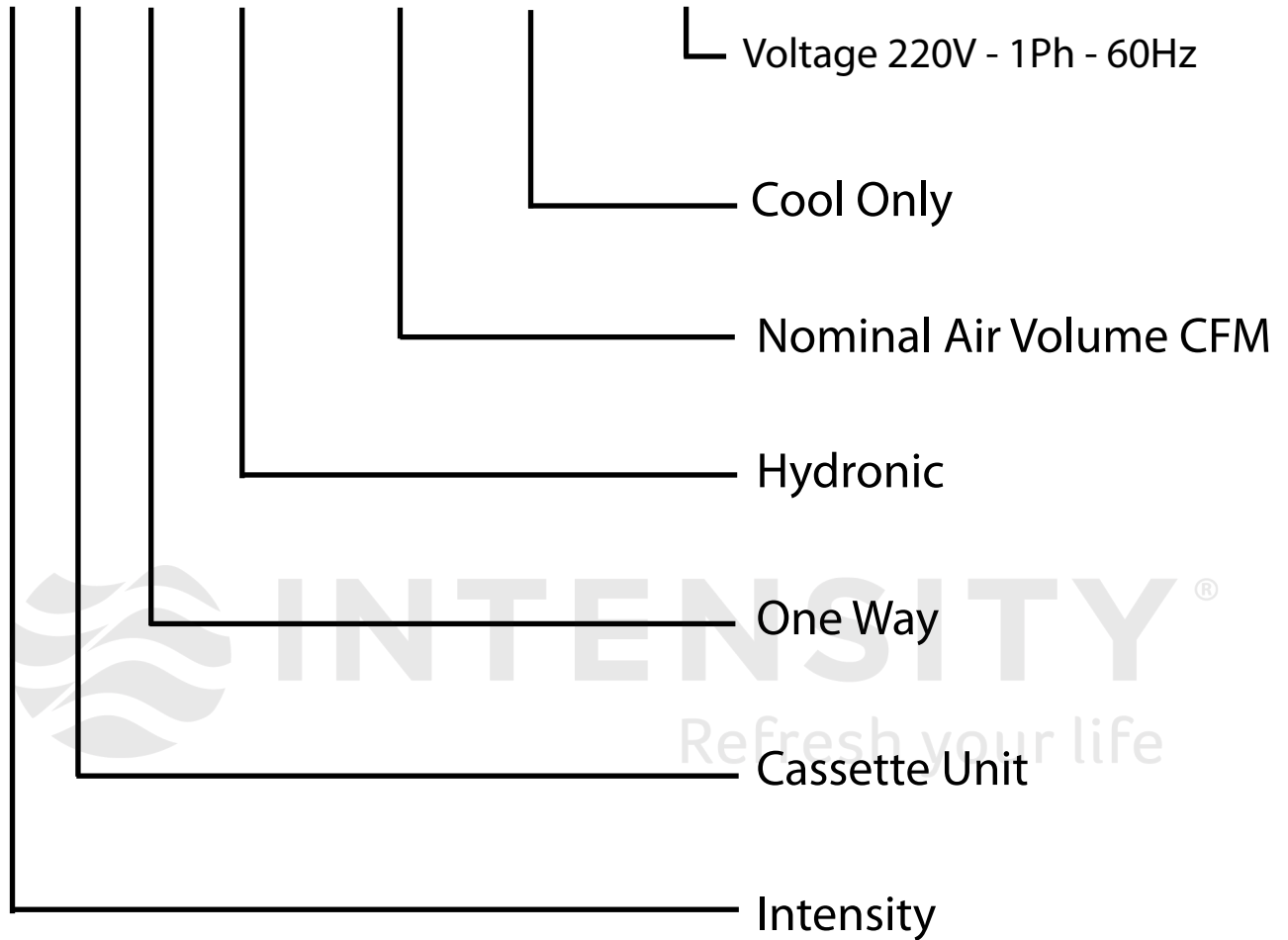

2. Features

2.1 New panel

---- The panel has digital display function, which can show temperature and warning message.



2.2 Compact design

---- Slim body needs only 153 mm space above the ceiling.

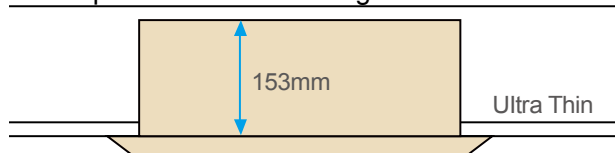

2.3 Improved air quality

---- Two folding type air filters and two standard formaldehyde absorption nets improve the air quality greatly. The design of a long air outlet and a wide guide fan blade, which enlarge the range of flow transportation.

2.4 Auto swing

---- Auto swing mechanism guarantees even airflow distribution and a better room temperature balance.

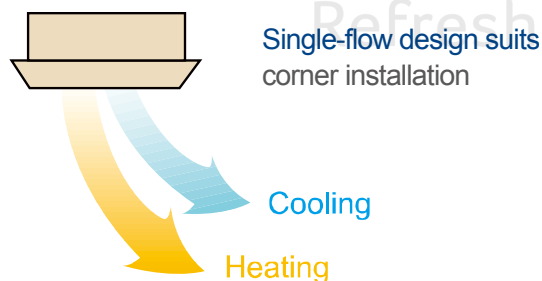

2.5 Built-in water pump with 750mm pump head.

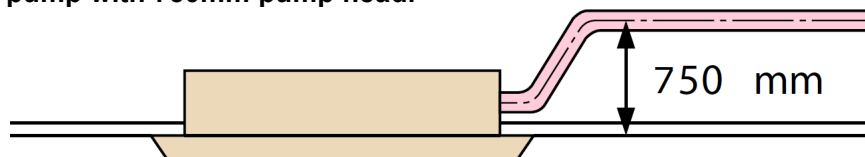

2.6 Prevent condensation in air outlet by the patent of a new structure design

--- By the adoption of this structure, the guide wing will always wrapped up by dry cold air, cutting off the contact route of moist hot air and the cold guide wing. As a result, the water vapour in moist hot air gets no change to condense in the surface of guide wing.

3. Specifications

Model			IC1H-04KF-3	
Air flow		H/M/L	m ³ /h	630/560/500
		H/M/L	CFM	370/330/300
Cooling	Capacity	H/M/L	kW	3.79/3.58/3.38
	Water flow rate	H	l/h	650
	Water pressure drop	H	kPa	20
Heating	Capacity	H/M/L	kW	6.41/5.86/5.11
	Water pressure drop	H	kPa	16
Power input		H	W	40
Electric heater capacity			W	750
Sound pressure level		H/M/L	dB(A)	37/35/34
Fan motor	Type			Low noise 4-speed fan motor
	Quantity			1
Fan	Type			Cross blow fan
	Quantity			1
Coil	Row			2
	Max. Working pressure		MPa	1.6
	Diameter		mm	Φ7
Panel	Dimensions	W×H×D	mm	1180x25x465
	Packing	W×H×D	mm	1232x107x517
	Net weight		Kg	3.5
	Gross weight		Kg	5.2
Body	Dimensions	W×H×D	mm	1053x170x425
	Net weight		* /A	12.8/13.1
	Packing	W×H×D	mm	1155x245x490
	Gross weight		* /A	16.6/17.1
Pipe connection	Water inlet/outlet pipe		Inch	G1/2
	Drain pipe		mm	ODΦ25

Notes: 1. H-high speed; M-medium speed; L-low speed.

2. Cooling conditions: entering water 7℃, temperature rise 5℃, entering air temperature 27℃DB/19℃WB.

Heating conditions: entering water 50℃, entering air temperature 20℃DB, the same water flow as the cooling conditions.

3. The noise is tested in the semi-anechoic test room.

4. Dimensions

IC1H-04KF-3

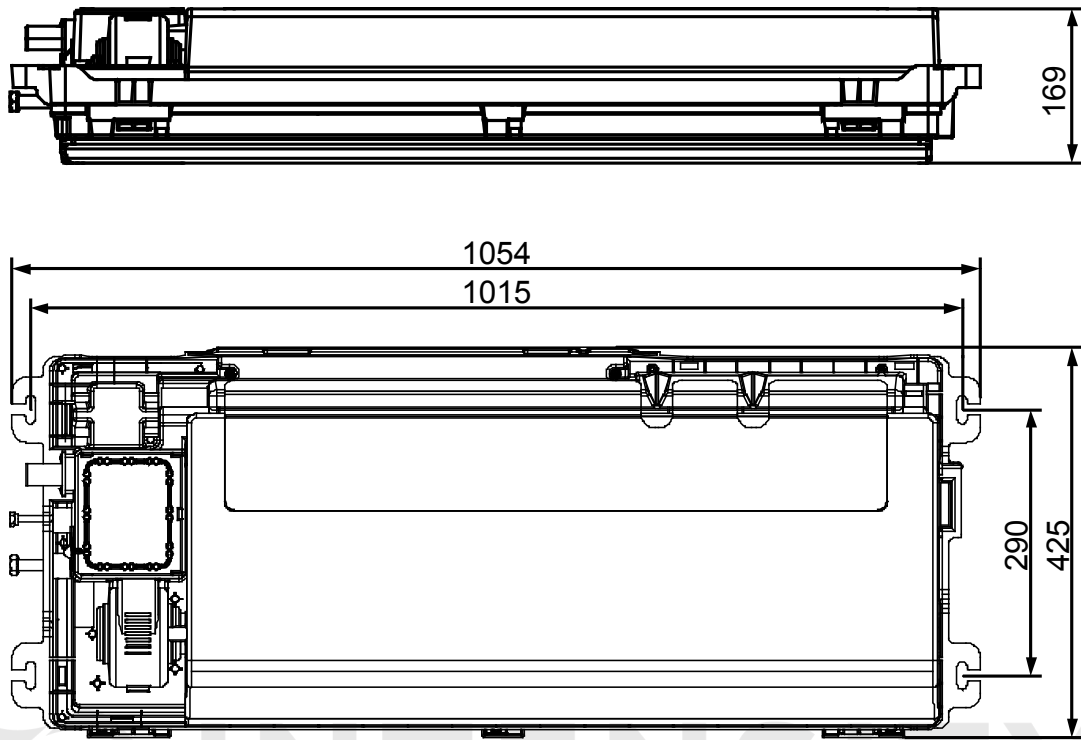

Please use the installation paper plate to make sure the position of the installation screws.

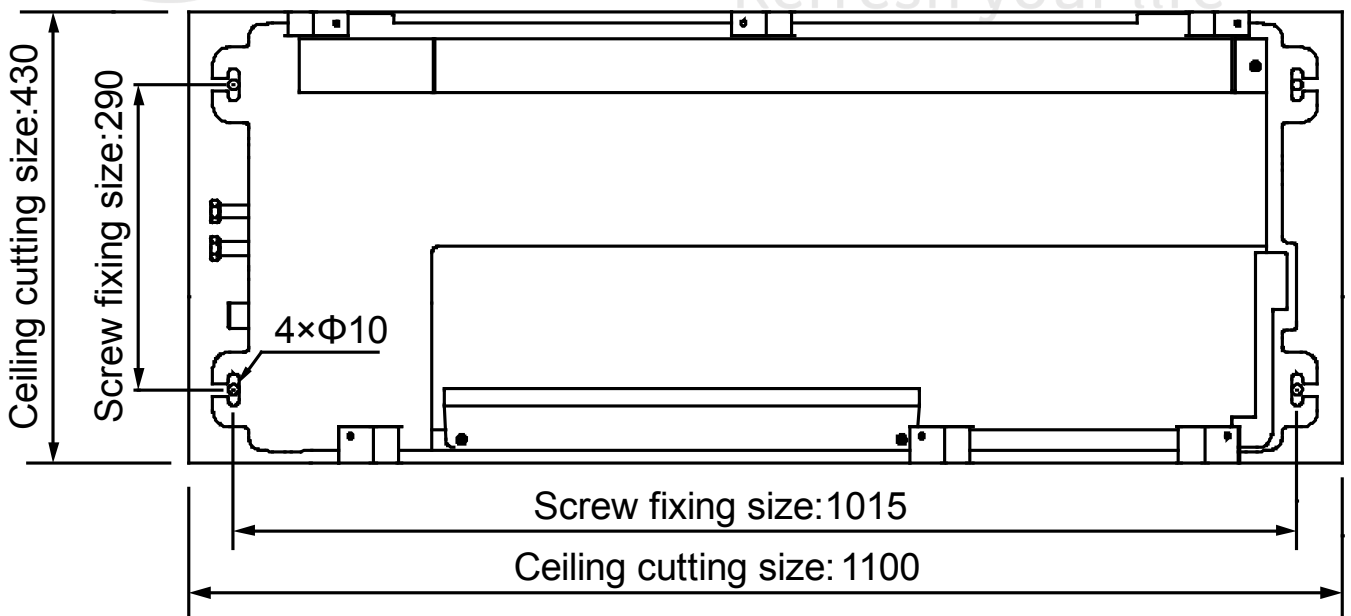

5. Service Spaces

Please avoid installing in the following places :

A place with flammable gas or material.

A saline place such as a seashore vicinity.

A place with sulphur gas.

A place with oil gas, such as kitchen.

A place with high-humidity air.

An unbearable place.

A place where high-frequency waves are generated.

The appliance shall not be installed in the laundry.

Please comply with the related national electric standard to make electric insulation for construction and metal parts of air-conditioner.

Please choose the place where the ventilation is good.

Ceiling space requires 170mm.

The installation height of the unit can not be higher than 3.2m, or it will affect the operation effect.

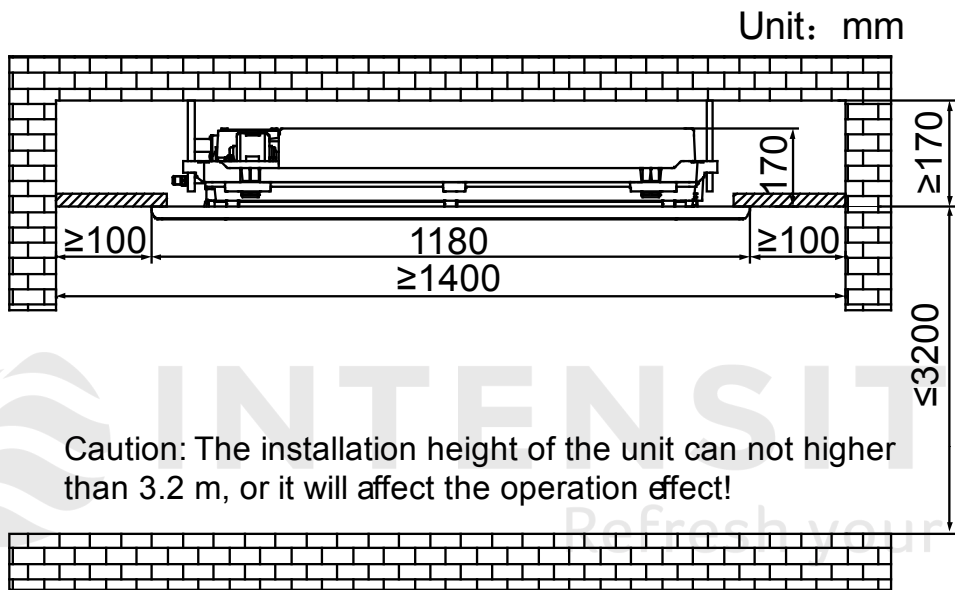

The air outlet can not has any barriers such as pendant lamp, folding screen etc.

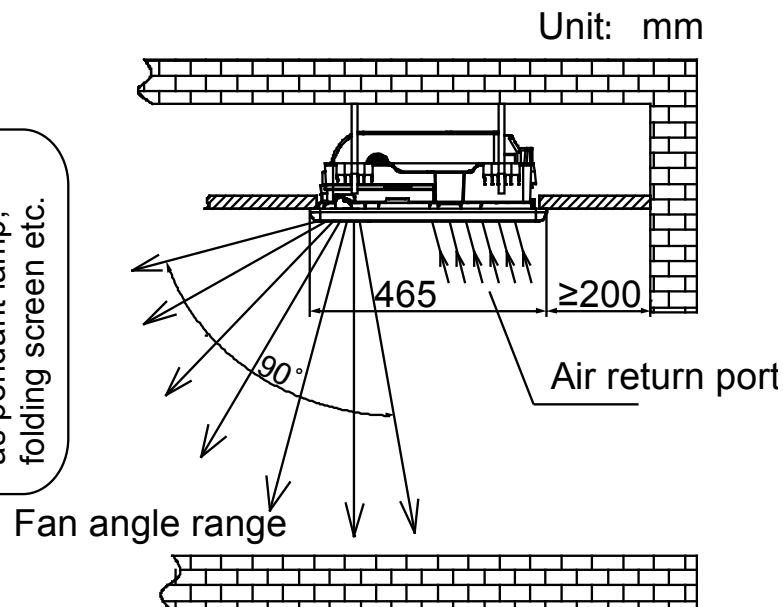

6. Wiring Diagrams IC1H-04KF-3

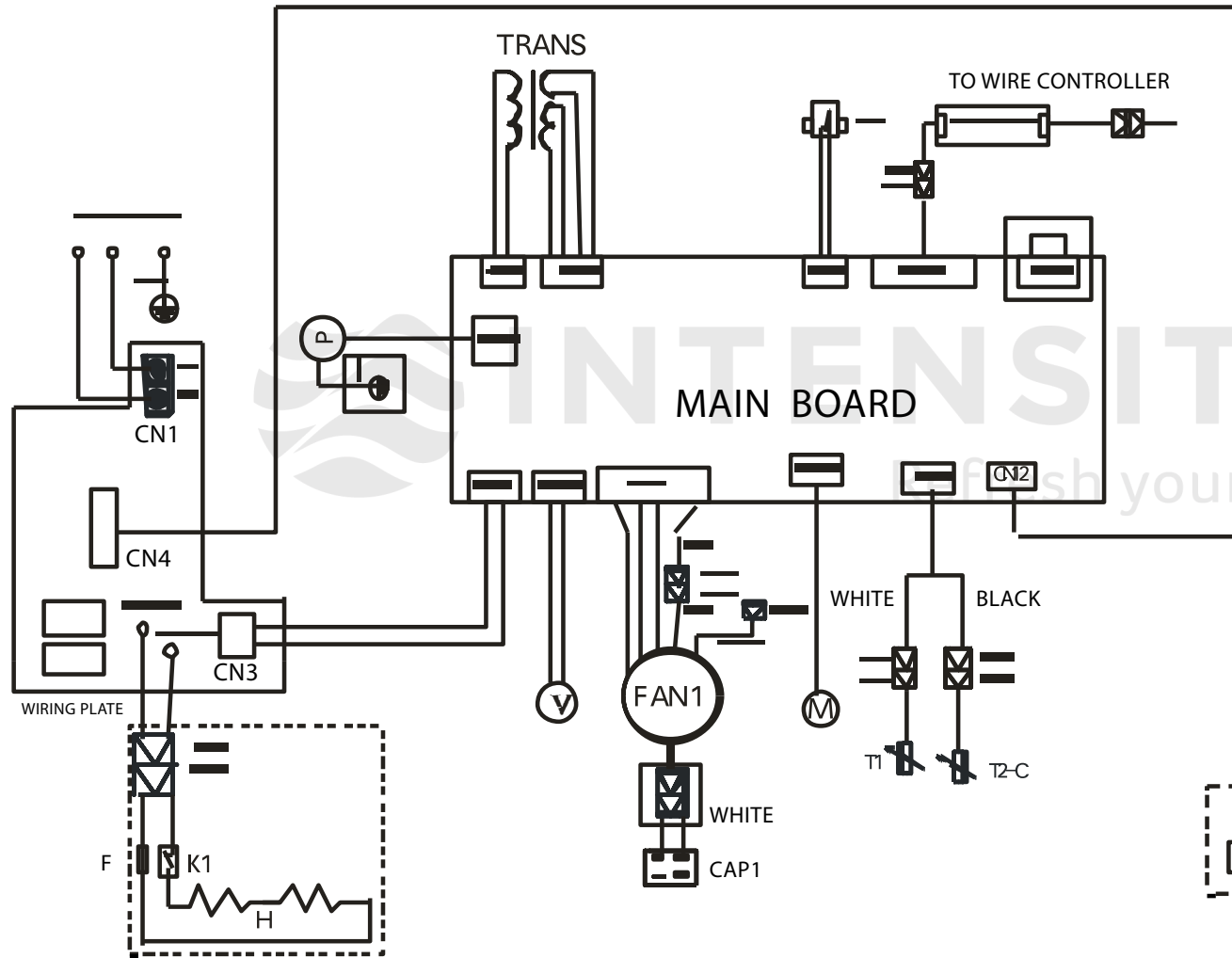

WIRING DIAGRAM

CODE	PART NAME
CAP1	INDOOR FAN CAPACITOR
CN1-22	P.C. BOARD SOCKETS
TRANS	POWER TRANSFORMER
FAN1	INDOOR FAN MOTOR
K3	WATER LEVEL SWITCH
M [®]	SWING MOTOR
P	PUMP
T1	ROOM TEMPERATURE
T2-C	PIPE TEMPERATURE
XP1-6	CONNECTORS
XS1-5	CONNECTORS
V	WATER VALVE ACTUATOR
H	ELECTRICAL HEATING
F	
K1	TEMPREATURE FUSE

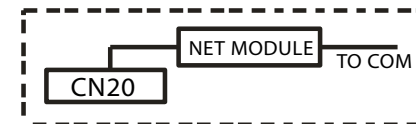

400

Inlet Water Temp.	Δt	Air inlet condition																			
		DB:21 WB:15				DB:26.7 WB:19.4				DB:27 WB:19				DB:29 WB:21				DB:33 WB:25			
		TC	SC	WF	WPD	TC	SC	WF	WPD	TC	SC	WF	WPD	TC	SC	WF	WPD	TC	SC	WF	WPD
5	3	3.13	2.28	0.90	27.44	4.83	2.91	1.38	65.17	4.73	3.04	1.36	62.54	5.28	2.77	1.51	77.99	7.11	3.45	2.04	141.25
	4	2.95	2.15	0.63	13.66	4.64	2.82	1.00	33.89	4.57	2.95	0.98	32.78	5.08	2.68	1.09	40.49	6.89	3.34	1.48	74.64
	5	2.72	2.06	0.47	7.46	4.44	2.72	0.76	19.84	4.35	2.85	0.75	19.06	4.88	2.59	0.84	23.94	6.67	3.28	1.15	44.78
	6	2.49	1.97	0.36	4.33	4.24	2.65	0.61	12.58	4.16	2.76	0.60	12.10	4.67	2.48	0.67	15.20	6.51	3.17	0.93	29.59
	7	2.23	1.84	0.27	2.56	4.04	2.52	0.50	8.36	3.94	2.66	0.48	7.98	4.47	2.38	0.55	10.25	6.29	3.06	0.77	20.30
	8	1.90	1.73	0.20	1.42	3.82	2.44	0.41	5.73	3.74	2.54	0.40	5.50	4.29	2.31	0.46	7.23	6.11	3.05	0.66	14.67
	9	1.54	1.50	0.15	0.73	3.61	2.34	0.34	4.04	3.51	2.46	0.34	3.82	4.12	2.24	0.39	5.26	5.89	2.83	0.56	10.78
6	3	2.83	2.14	0.81	22.43	4.56	2.79	1.31	57.99	4.45	2.91	1.28	55.38	5.02	2.65	1.44	70.28	6.84	3.34	1.96	130.59
	4	2.63	2.04	0.57	10.88	4.38	2.70	0.94	30.09	4.27	2.82	0.92	28.68	4.81	2.56	1.03	36.41	6.62	3.23	1.42	68.83
	5	2.43	1.95	0.42	5.93	4.16	2.60	0.72	17.42	4.08	2.73	0.70	16.74	4.62	2.46	0.79	21.48	6.40	3.12	1.10	41.19
	6	2.18	1.86	0.31	3.33	3.97	2.52	0.57	10.98	3.87	2.63	0.55	10.47	4.39	2.35	0.63	13.47	6.23	3.01	0.89	27.15
	7	1.92	1.73	0.24	1.89	3.76	2.41	0.46	7.25	3.66	2.56	0.45	6.89	4.19	2.25	0.52	9.03	6.02	2.95	0.74	18.58
	8	1.62	1.62	0.17	1.03	3.53	2.29	0.38	4.90	3.45	2.45	0.37	4.68	4.03	2.17	0.43	6.37	5.84	2.86	0.63	13.40
	9	1.08	1.08	0.10	0.36	3.31	2.22	0.32	3.41	3.21	2.34	0.31	3.20	3.87	2.11	0.37	4.64	5.57	2.78	0.53	9.63
7	3	2.53	2.01	0.73	17.92	4.25	2.66	1.22	50.59	4.16	2.79	1.19	48.40	4.72	2.52	1.35	62.25	6.51	3.17	1.87	118.36
	4	2.32	1.94	0.50	8.49	4.08	2.56	0.88	26.16	3.97	2.70	0.85	24.78	4.53	2.43	0.97	32.31	6.34	3.12	1.36	63.26
	5	2.10	1.84	0.36	4.44	3.87	2.47	0.67	15.08	3.79	2.61	0.65	14.45	4.32	2.34	0.74	18.73	6.13	3.01	1.05	37.74
	6	1.85	1.75	0.26	2.39	3.67	2.40	0.53	9.41	3.60	2.52	0.52	9.07	4.12	2.23	0.59	11.85	5.96	2.90	0.85	24.83
	7	1.60	1.60	0.20	1.32	3.47	2.29	0.43	6.19	3.36	2.44	0.41	5.79	3.90	2.14	0.48	7.80	5.74	2.79	0.71	16.92
	8	1.37	1.37	0.15	0.74	3.24	2.21	0.35	4.14	3.14	2.32	0.34	3.86	3.74	2.05	0.40	5.51	5.51	27.57	0.59	11.95
	9	0.94	0.94	0.09	0.28	2.98	2.09	0.29	2.77	2.89	2.23	0.28	2.60	3.59	1.99	0.34	4.01	5.32	26.60	0.51	8.79
8	3	2.22	1.91	0.64	13.78	3.97	2.54	1.14	43.93	3.87	2.66	1.11	41.90	4.44	2.38	1.27	54.97	6.23	3.06	1.79	108.62
	4	2.00	1.85	0.43	6.30	3.79	2.46	0.81	22.58	3.68	2.60	0.79	21.23	4.22	2.31	0.91	28.02	6.02	2.95	1.29	56.89
	5	1.77	1.73	0.30	3.16	3.60	2.35	0.62	13.03	3.49	2.49	0.60	12.25	4.04	2.21	0.70	16.43	5.85	2.84	1.01	34.45
	6	1.59	1.59	0.23	1.77	3.36	2.28	0.48	7.90	3.30	2.41	0.47	7.60	3.84	2.11	0.55	10.30	5.63	2.79	0.81	22.17
	7	1.39	1.39	0.17	0.99	3.17	2.18	0.39	5.15	3.07	2.32	0.38	4.83	3.59	2.02	0.44	6.63	5.44	2.69	0.67	15.17
	8	0.92	0.92	0.10	0.33	3.07	2.18	0.33	3.70	2.84	2.21	0.31	3.17	3.45	1.91	0.37	4.68	5.24	2.62	0.56	10.81
	9	0.82	0.82	0.08	0.21	2.88	2.16	0.28	2.58	2.56	2.15	0.24	2.03	3.31	1.98	0.32	3.40	5.02	2.51	0.48	7.82
9	3	1.90	1.80	0.54	10.06	3.69	2.43	1.06	37.97	3.58	2.55	1.03	35.86	4.14	2.26	1.19	47.90	5.96	2.95	1.71	99.30
	4	1.72	1.72	0.37	4.66	3.48	2.34	0.75	19.02	3.37	2.47	0.73	17.90	3.93	2.18	0.84	24.24	5.74	2.84	1.23	51.83
	5	1.59	1.54	0.27	2.55	3.29	2.24	0.57	10.90	3.19	2.39	0.55	10.23	3.74	2.08	0.64	14.04	5.58	2.73	0.96	31.30
	6	1.39	1.39	0.20	1.36	3.07	2.16	0.44	6.60	2.96	2.31	0.42	6.14	3.54	1.99	0.51	8.75	5.34	2.67	0.77	19.94
	7	1.14	1.14	0.14	0.66	2.84	2.06	0.35	4.15	2.75	2.21	0.34	3.87	3.29	1.90	0.40	5.56	5.16	2.58	0.63	13.68
	8	0.80	0.80	0.09	0.25	2.65	2.02	0.29	2.77	2.48	2.13	0.27	2.42	3.16	1.93	0.34	3.93	4.95	2.52	0.53	9.62
	9	0.68	0.68	0.07	0.14	2.46	2.02	0.24	1.88	2.16	2.05	0.21	1.45	3.03	1.91	0.29	2.86	4.71	2.40	0.45	6.90
10	3	1.67	1.67	0.48	7.83	3.38	2.30	0.97	31.92	3.24	2.46	0.93	29.39	3.85	2.14	1.10	41.42	5.69	2.79	1.63	90.40
	4	1.54	1.54	0.33	3.71	3.17	2.21	0.68	15.82	3.06	2.37	0.66	14.74	3.63	2.06	0.78	20.67	5.45	2.73	1.17	46.73
	5	1.37	1.37	0.24	1.90	2.96	2.14	0.51	8.84	2.84	2.30	0.49	8.10	3.43	1.97	0.59	11.87	5.28	2.64	0.91	28.08
	6	1.18	1.18	0.17	0.97	2.76	2.05	0.40	5.33	2.64	2.21	0.38	4.85	3.21	1.87	0.46	7.20	5.05	2.56	0.72	17.84
	7	0.75	0.75	0.09	0.29	2.52	1.96	0.31	3.26	2.40	2.13	0.29	2.96	3.00	1.78	0.37	4.63	4.83	2.46	0.59	11.97
	8	/	/	/	/	2.39	2.01	0.26	2.24	2.08	2.08	0.22	1.70	2.88	1.82	0.31	3.26	4.64	2.37	0.50	8.46
	9	/	/	/	/	2.16	2.07	0.21	1.45	1.92	1.92	0.18	1.14	2.77	1.80	0.26	2.38	4.42	2.30	0.42	6.06
11	3	1.48	1.48	0.42	6.09	3.05	2.20	0.87	26.02	2.94	2.34	0.84	24.19	3.54	2.03	1.01	34.99	5.37	2.69	1.54	80.43
	4	1.35	1.35	0.29	2.87	2.86	2.12	0.61	12.86	2.75	2.25	0.59	11.85	3.34	1.95	0.72	17.55	5.15	2.61	1.11	41.63
	5	1.17	1.17	0.20	1.38	2.64	2.04	0.45	7.02	2.52	2.20	0.43	6.39	3.12	1.85	0.54	9.81	4.98	2.52	0.86	24.97
	6	0.93	0.93	0.13	0.60	2.41	1.96	0.34	4.05	2.31	2.10	0.33	3.74	2.90	1.76	0.42	5.87	4.75	2.46	0.68	15.78
	7	0.63	0.63	0.08	0.20	2.14	1.89	0.26	2.36	2.07	2.07	0.25	2.19	2.67	1.66	0.33	3.66	4.53	2.35	0.56	10.55
	8	/	/	/	/	1.83	1.80	0.20	1.32	1.91	1.91	0.21	1.44	2.56	1.67	0.28	2.58	4.35	2.26	0.47	7.43
	9	/	/	/	/	1.64	1.61	0.16	0.84	1.71	1.71	0.16	0.91	2.46	1.65	0.24	1.88	4.13	2.19	0.39	5.28
12	3	1.30	1.30	0.37	4.73	2.73	2.09	0.78	20.81	2.60	2.26	0.74	18.86	3.22	1.92	0.92	28.90	5.06	2.58	1.45	71.67
	4	1.15	1.15	0.25	2.07	2.53	2.02	0.54	10.03	2.40	2.18	0.52	9.06	3.02	1.83	0.65	14.38	4.85	2.50	1.04	36.99

	5	0.99	0.99	0.17	0.99	2.31	1.95	0.40	5.36	2.19	2.11	0.38	4.81	2.81	1.75	0.48	7.92	4.67	2.41	0.80	21.89
	6	0.60	0.60	0.09	0.25	2.05	1.89	0.29	2.94	2.03	1.99	0.29	2.88	2.57	1.65	0.37	4.62	4.44	2.34	0.64	13.78
	7	0.49	0.49	0.06	0.12	1.82	1.82	0.22	1.69	1.87	1.87	0.23	1.80	2.34	1.55	0.29	2.80	4.22	2.25	0.52	9.15
	8	/	/	/	/	1.63	1.63	0.18	1.05	1.70	1.70	0.18	1.13	2.24	1.55	0.24	1.97	4.02	2.17	0.43	6.34
	9	/	/	/	/	1.42	1.42	0.14	0.62	1.49	1.49	0.14	0.69	2.15	1.55	0.21	1.44	3.77	2.08	0.36	4.42
13	3	1.12	1.12	0.32	3.51	2.38	2.00	0.68	15.89	2.25	2.17	0.64	14.12	2.90	1.81	0.83	23.48	4.74	2.48	1.36	62.83
	4	0.96	0.96	0.21	1.44	2.18	1.93	0.47	7.48	2.11	2.07	0.45	6.97	2.69	1.72	0.58	11.38	4.54	2.38	0.98	32.39
	5	0.69	0.69	0.12	0.48	1.95	1.90	0.33	3.81	1.97	1.97	0.34	3.90	2.48	1.64	0.43	6.17	4.34	2.29	0.75	18.92
	6	0.46	0.46	0.07	0.15	1.77	1.77	0.25	2.19	1.83	1.83	0.26	2.34	2.24	1.55	0.32	3.50	4.11	2.23	0.59	11.82
	7	0.34	0.34	0.04	0.06	1.62	1.62	0.20	1.35	1.68	1.68	0.21	1.46	1.96	1.47	0.24	1.97	3.90	2.14	0.48	7.80
	8	/	/	/	/	1.42	1.42	0.15	0.79	1.50	1.50	0.16	0.88	1.88	1.39	0.20	1.39	3.69	2.03	0.40	5.34
	9	/	/	/	/	1.15	1.15	0.11	0.41	1.24	1.24	0.12	0.48	1.80	1.44	0.17	1.01	3.44	1.96	0.33	3.67
14	3	/	/	/	/	2.00	1.94	0.57	11.18	2.03	2.03	0.58	11.49	2.61	1.96	0.75	19.01	4.44	2.35	1.27	55.06
	4	/	/	/	/	1.87	1.83	0.40	5.47	1.92	1.92	0.41	5.79	2.37	1.85	0.51	8.85	4.22	2.28	0.91	28.03
	5	/	/	/	/	1.87	1.87	0.32	3.50	1.79	1.79	0.31	3.22	2.16	1.77	0.37	4.70	4.00	2.24	0.69	16.06
	6	/	/	/	/	1.87	1.87	0.27	2.43	1.64	1.64	0.23	1.87	1.93	1.64	0.28	2.61	3.80	2.13	0.54	10.06
	7	/	/	/	/	1.41	1.41	0.17	1.02	1.47	1.47	0.18	1.11	1.61	1.42	0.20	1.34	3.58	2.04	0.44	6.57
	8	/	/	/	/	1.87	1.87	0.20	1.37	1.27	1.27	0.14	0.63	1.54	1.42	0.17	0.93	3.34	1.97	0.36	4.39
	9	/	/	/	/	0.78	0.78	0.07	0.19	0.81	0.81	0.08	0.20	1.48	1.41	0.14	0.68	3.09	1.88	0.29	2.96
15	3	/	/	/	/	/	/	/	/	/	/	/	/	/	/	/	/	4.10	2.26	1.18	47.06
	4	/	/	/	/	/	/	/	/	/	/	/	/	/	/	/	/	3.90	2.18	0.84	23.88
	5	/	/	/	/	/	/	/	/	/	/	/	/	/	/	/	/	3.67	2.13	0.63	13.56
	6	/	/	/	/	/	/	/	/	/	/	/	/	/	/	/	/	3.47	2.05	0.50	8.42
	7	/	/	/	/	/	/	/	/	/	/	/	/	/	/	/	/	3.23	1.94	0.40	5.37
	8	/	/	/	/	/	/	/	/	/	/	/	/	/	/	/	/	2.99	1.88	0.32	3.51
	9	/	/	/	/	/	/	/	/	/	/	/	/	/	/	/	/	2.75	1.79	0.26	2.35



INTENSITY
Refresh your life

7. Capacity Tables

7.2 Heating

Remark:

Δt: Temperature Difference (°C); **TH:** Total Heating Capacity (kW); **WF:** Water Flow (m³/h); **WPD:** Water Pressure Drop (kPa)

400																											
Air inlet temp. (20°C DB)																											
Water inlet temp. (°C)																											
Δt	35			40			45			50			55			60			65			70			75		
	TH	WF	WPD	TH	WF	WPD	TH	WF	WPD	TH	WF	WPD	TH	WF	WPD	TH	WF	WPD	TH	WF	WPD	TH	WF	WPD	TH	WF	WPD
°C	kW	m ³ /h	kPa	kW	m ³ /h	kPa	kW	m ³ /h	kPa	kW	m ³ /h	kPa	kW	m ³ /h	kPa	kW	m ³ /h	kPa	kW	m ³ /h	kPa	kW	m ³ /h	kPa	kW	m ³ /h	kPa
20	—	—	—	—	—	—	1.85	0.08	0.2	4.26	0.18	1.3	5.76	0.25	2.4	7.17	0.31	3.7	8.50	0.37	5.1	9.91	0.43	7.0	1.66	0.07	0.2
15	—	—	—	—	—	—	3.91	0.22	1.9	5.33	0.31	3.6	6.65	0.38	5.6	8.02	0.46	8.1	9.20	0.53	10.7	10.70	0.61	14.5	1.75	0.10	0.4
10	2.24	0.19	1.4	3.52	0.30	3.5	4.87	0.42	6.7	6.14	0.53	10.7	7.43	0.64	15.7	8.73	0.75	21.7	9.99	0.86	28.4	11.25	0.97	36.0	1.85	0.16	1.0
8	2.49	0.27	2.7	3.87	0.42	6.7	5.18	0.56	11.9	6.47	0.70	18.6	7.71	0.83	26.4	8.97	0.96	35.7	10.23	1.10	46.5	11.49	1.23	58.6	1.90	0.20	1.6
6	2.88	0.41	6.6	4.19	0.60	13.9	5.44	0.78	23.3	6.75	0.97	36.0	8.02	1.15	50.9	9.28	1.33	68.1	10.46	1.50	86.5	11.80	1.69	110.0	1.95	0.28	3.0



8. Exploded View

IC1H-04KF-3

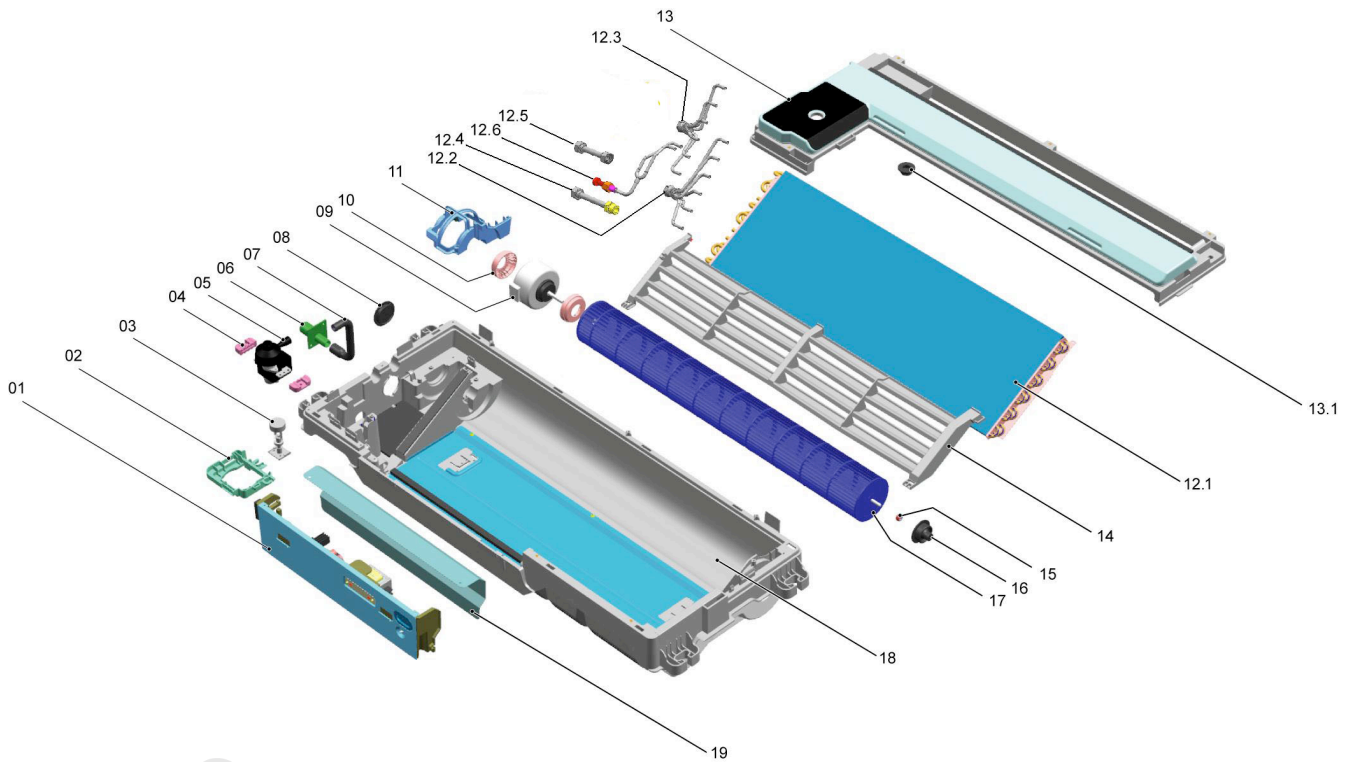

No.	Part Name	Qty	No.	Part Name	Qty
1	E-part box ass'y	1	11	Motor bracket	1
1.1	Electric control box of fire protection shell welded pieces	1	12	Evaporator ass'y	1
1.2	Middle wiring board	1	12.1	Outlet valve ass'y	1
1.3	Power transformer	1	12.2	Inlet valve ass'y	1
1.4	Motor capacitor	1	12.3	Evaporator	1
1.5	Main control board ass'y	1	12.4	Inlet pipe ass'y	1
1.6	Electronic control box	1	12.5	Inlet connect pipe ass'y	1
2	Drainage pump bracket	1	12.6	Exhaust valve	1
3	Water Level Switch	1	13	Drain tray	1
4	Drainage pump shock pad	2	13.1	Drain plug	1
5	Drainage pump	1	14	Auxiliary drainage pan	1
6	Connecting pipe	1	15	Bearing ball	1
7	Drain pipe	1	16	Bearing base	1
8	Water cover ass'y	1	17	Cross fan	1
9	Asynchronous motor	1	18	Chassis Parts	1
10	AC motor reducing sleeve	2	19	E-Part box cover	1

9. Installation

9.1 Installation space

- Please avoid installing in the following places
- A place with flammable gas or material.
- A saline place such as a seashore vicinity
- A place with sulphur gas.
- A place with oil gas, such as kitchen.
- A place with high-humidity air.
- An unbearable place.
- A place where high-frequency waves are generated.
- The appliance shall not be installed in the laundry.
- Please comply with the related national electric standard to make electric insulation for construction and metal parts of air-conditioner.
- Please choose the place where the ventilation is good.
- Ceiling space requires $\geq 170\text{mm}$;
- The installation height of the unit can not higher than 3.2 m, or it will affect the operation effect.

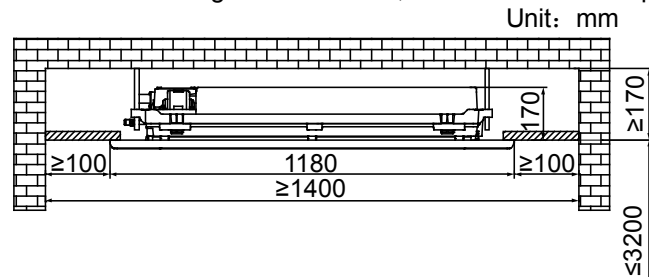

Caution: The installation height of the unit can not higher than 3.2 m, or it will affect the operation effect!

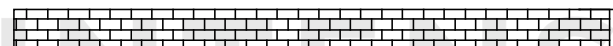

INTENSITY®
Refresh your life

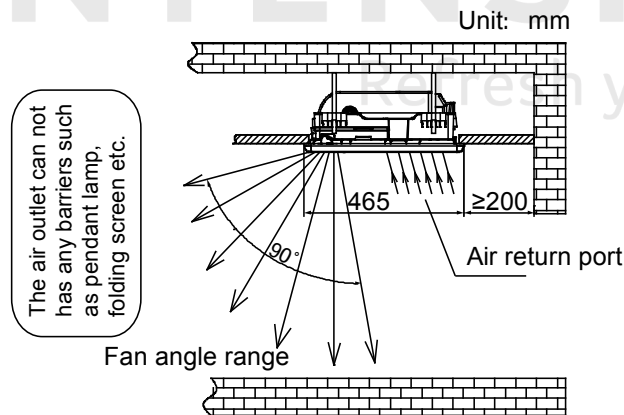

9.2 Unit installation

- Please use the installation paper plate to make sure the positions of the installation screws.

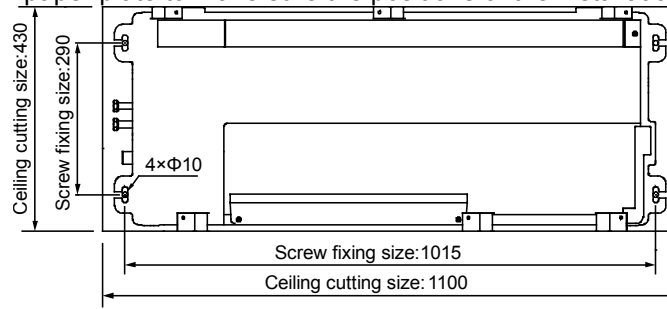

- Please accord to the follow figure's requirements to design the length of the suspender bolt.

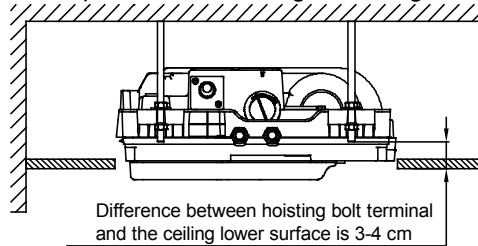

- Please install with $\Phi 10$ hanging screw bolts.
- The handling to the ceiling varies from the constructions, consult the construction person for the specific condition.
- The size of the ceiling to be handled----- Do keep the ceiling flat. Consolidate the roof beam for possible vibration.
- Cut off the roof beam.
- Strengthen the place that has been cut off, and consolidate the roof beam.
- Connect wires and pipes inside the ceiling after the air conditioner is hanged.
- After the selection of installation location, position the refrigerant pipes, drain pipes, indoor & outdoor wires to the connection places before hanging up the machine.
- The installation of hanging screw bolts.
 - Wooden construction
 - Put the square timber over the roof beam, then install the hanging screw bolts.

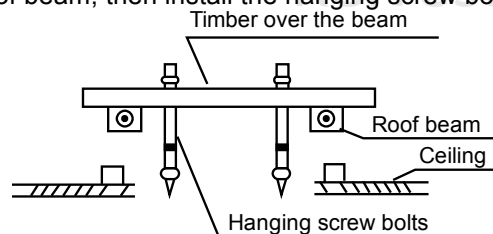

- New Concrete Bricks
- Inlaying or embedding the screw bolts.

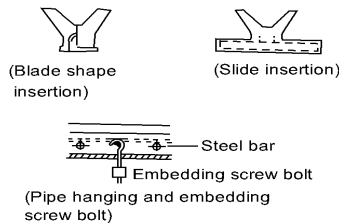

- For finished concrete bricks

Install the hanging hook with expansible bolt into the concrete deep to 45~50mm to prevent loose.

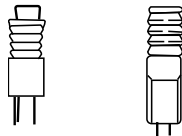

- Steel roof beam structure

Install the supporting angle steel.

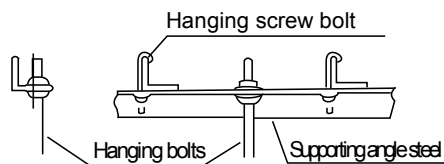

■ Hoisting the indoor unit

- Adjust the height of screw 2, to make the difference between the upper surface of gasket 2 and the lower surface of the ceiling is 70mm;

- Hoisting the unit on the suspender bolt as the follow figure display, use the level gauge to level-out the length and width directions, and it needs to repeatedly adjust four screw 2 of the suspender during the process. It might occur this situation: under making sure the unit level, the difference of four gasket 2 of the hoisting bolt and the lower surface of the ceiling will be discorded, can not be 70mm. At this time it should make sure the level of the unit body, and move the whole unit up and down, and make the four differences try to be close to 70mm;

- Finish adjusting the unit height and the level, fasten the screw 1 of the four suspenders, and make the unit fixed reliably.

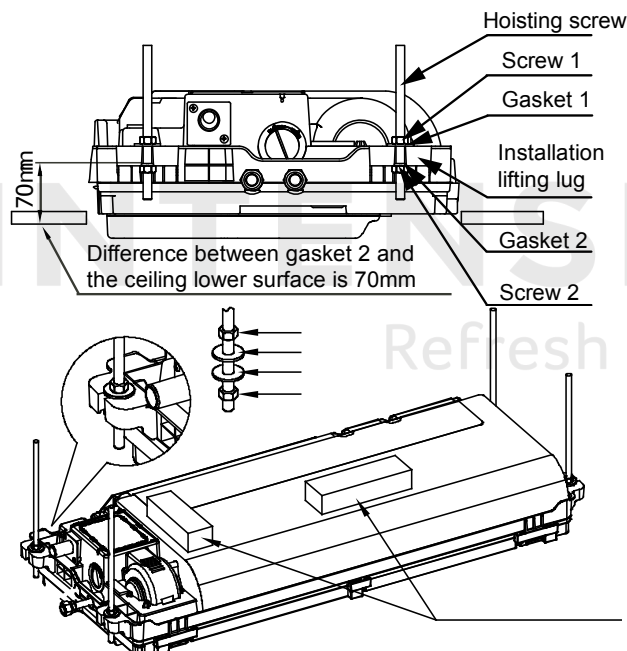

■ Cutting the ceiling

- Fold the installation paper plate. Caution: Folding direction is bulged out from the no printing content side;

- Use the panel fixing screws to fix the installation paper plate under the indoor unit;

- Make the ceiling opening size be the same with the outboard size of the model paper;

- Make sure the difference between the lower sides of the ceiling and model paper plate to be about 24mm, if not fit the requirements then means the hoisting height has problem.

Please back to the above steps to re-adjust.

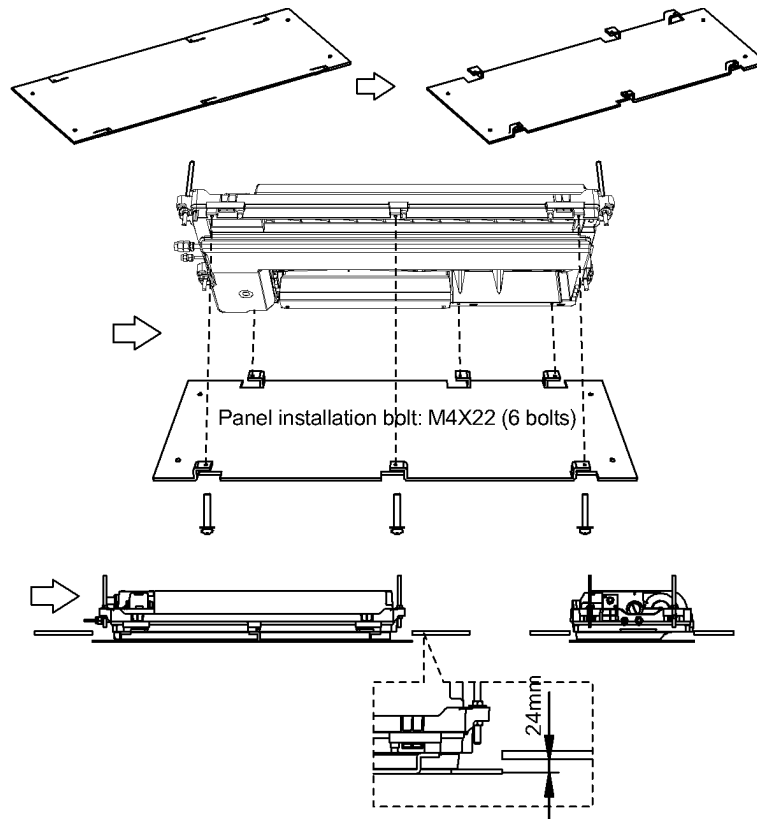

■ Panel component installation

■ Remove the air return grille, filter screen, screw hidden cover.

- As the grille switch arrow indication direction to pull the lock catch, remove the air return grille.
- Pull the buckle as figure display, remove the filter screen.
- Open the air leading bar, remove three screw hidden covers.
- Take down the air return grille, filter screen, screw hidden cover and please safely keep them, do not lose, dirt and damage them.

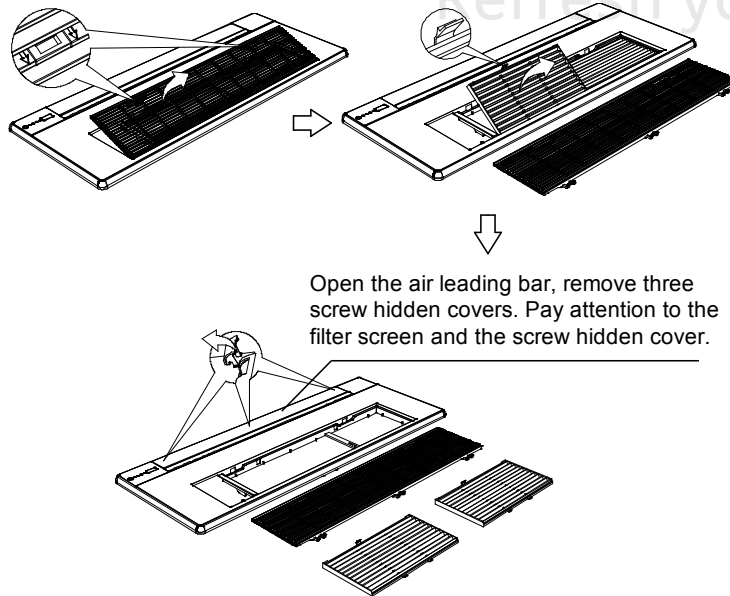

- Install the panel component, and wiring
- Two buckles on the panel component are used for assisting the panel installation, the installing method of the buckle as the follow figure display.
- Panel component wiring: open the electric control panel, connect the wiring terminal of the control display box and the motor connecting terminal of the air leading bar as the figure display to the main control panel.

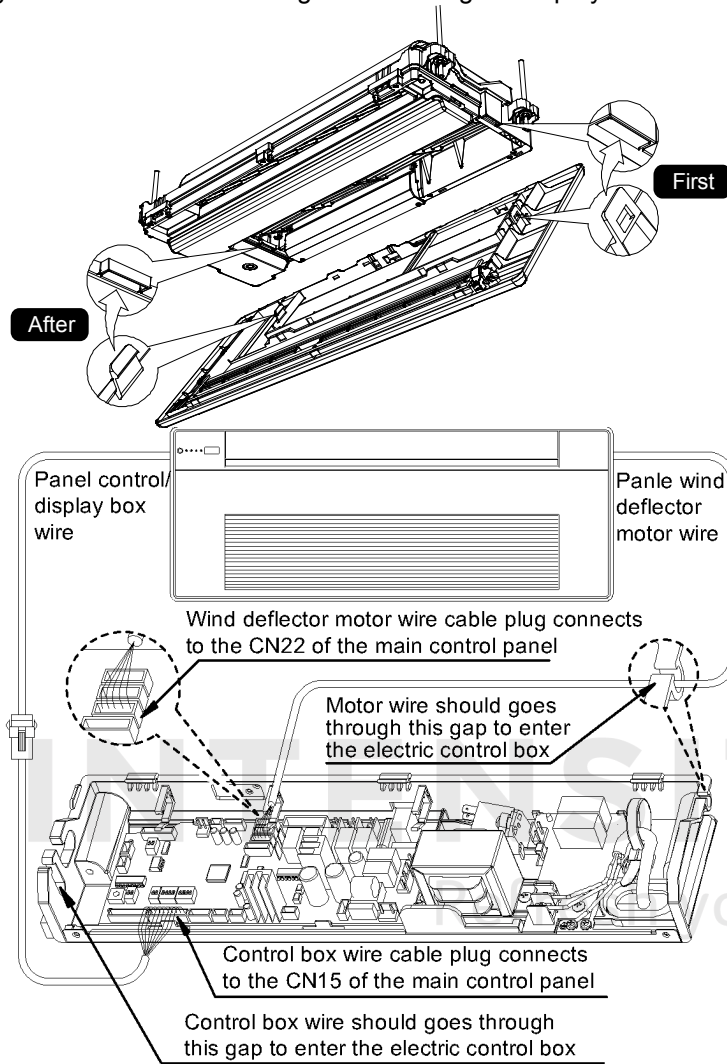

■ Install the screw

- Before installation please check the connecting cable between panel and air conditioner whether has clamped, if clamped, the panel will be unfairness after fastening the screws and damage the wires.

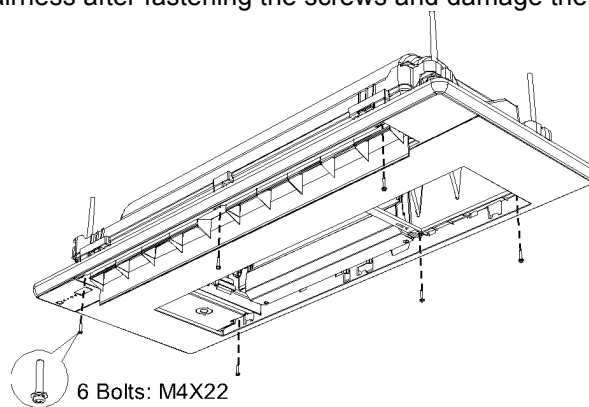

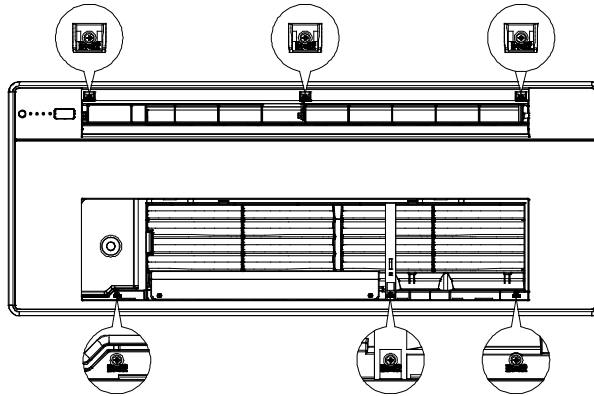

- Install the screw hidden cover

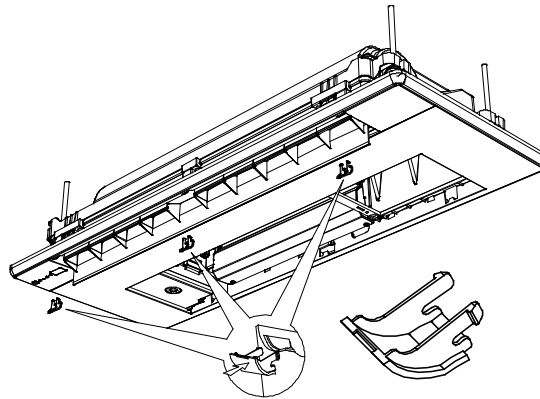

Screw hidden cover

- Install back the filter screen and the air return grille

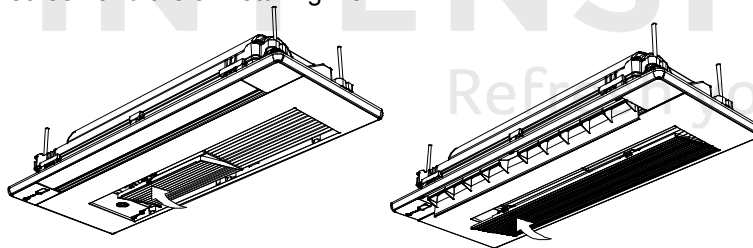

- Panel component wiring must accord to the figure display, otherwise will cause the abnormal operation. Connecting wire installation must follow the figure display, otherwise will cause the electric control box cover can't close, if there are wire clamped will cause air leakage and condensation of the panel and so on.
- Display part of the panel should be installed at the pipe side of the unit body.
- There are 6 panel installation screws, after confirmation then to be fastened.

9.3 Drainpipe installation

When connecting the pipe, please use the sealing material and pipe glove.

- The drain pipe of indoor unit must be heat insulated, or it will condense dew, as well as the connections of the indoor unit.
- Make sure the connections is no leakage.
- With the connection part to the indoor unit, please note not to impose pressure on the side of indoor unit pipes.
- When the declivity of the drain pipe downwards is over 1/100, there should not be any winding.
- The total length of the drain pipe when pulled out breadthwise shall not exceed 20m. When the pipe is over long, a bracket must be installed to prevent winding.
- Refer to the following figures to install the pipes.
- Drainage system type

- Centralized drainage of several air conditioners

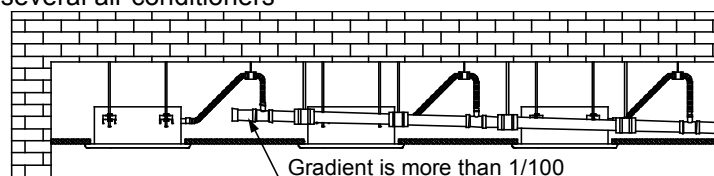

●Single air conditioner drainage

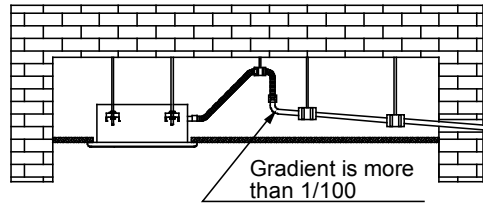

■ Drainage system design requirement

●Between climbing section length (L) and pipe inner diameter (d) should satisfy the relation: $L \cdot d \leq 650000$ (L and d units are mm). that is water in the climbing section can not more than 500 ml, otherwise will cause poor drainage, flowing water leakage problems.

●It must accord to the requirement to install the water pipe. Suggest using water pipe with the inner diameter 25mm, and the climbing length is not over than 1m.

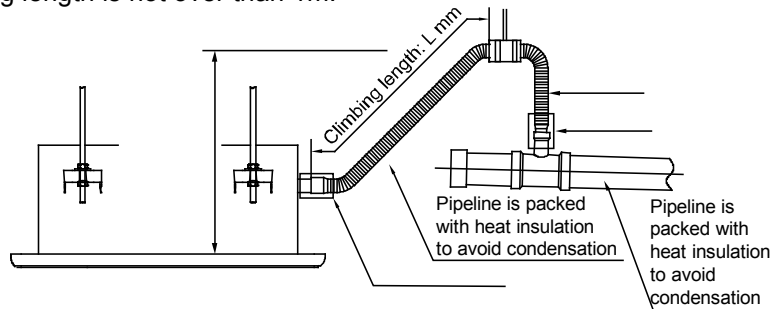

■ Please according to the tube hardness to choose proper support density, do not appear obvious dropping and deformation situation. Dropping part will save the water and lead to poor drainage and abnormal noise.

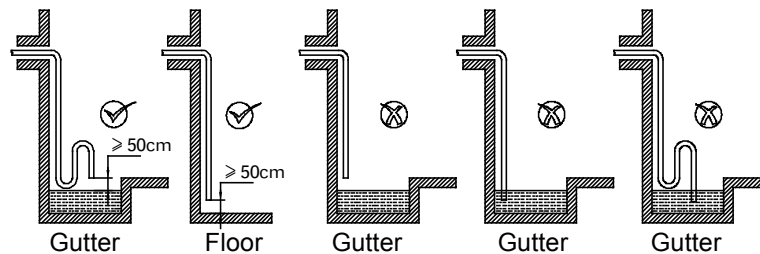
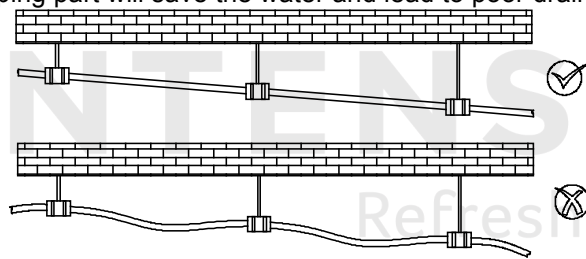
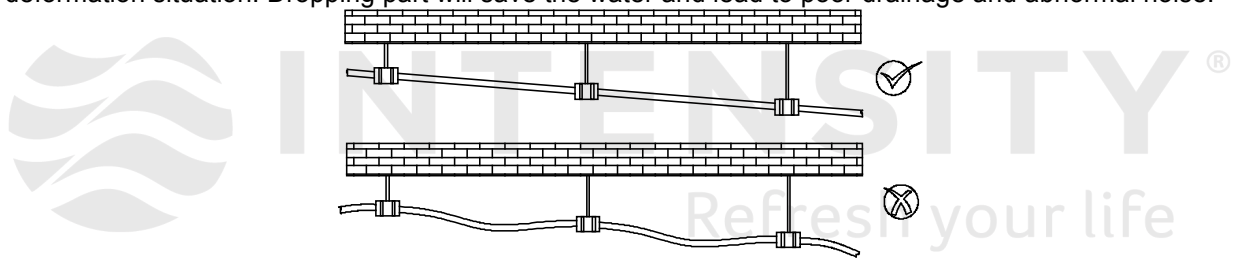

■ Drainage system design requirement

- Drainage pipe can use PVC pipe, recommended to use the pipe of 25 mm inner diameter, water pipe should have thermal insulation layer.
- The user can purchase the pipe of suitable length in the dealer place or in a local after-sale service center place, or directly to purchase in the market.
- Insert the drainage pipe port to the condensate water outlet, and use the outlet clamp (accessory) to fasten the drainage pipe and the thermal insulation sleeve.
- The pipes are needed to be packed with insulation heat preservation material. The connection of water pipe and air conditioner should use insulating sheath package, and tighten tightly to prevent water condensation to damage the ceiling decoration.
- To avoid water poured into the air conditioner inside when the unit operation stops, drainage pipe should be down dipped to outdoor side (drainage side), gradient is more than 1/100, drainage pipeline can not occur bending and dropping save water phenomenon, otherwise it will cause abnormal noise.
- During connecting pipe, please do not force pulling the drainage pipe which will cause the nozzle loose, and at the same time shall set up enough strong points, in order to avoid the drainage pipe drops.

■ Drainage test

- After the unit installation then do the trial run and water drainage test. Power on the indoor and outdoor unit; operate the cooling mode and do the water drainage test.
- Open the cover of water test hole, use bottle or flexible pipe to fill water (500ml/min.), and then to observe whether has water drain out from the water drainage port. Check whether the pipeline has leakage and places which not pack with thermal material, and improve the parts with problems.
- After finishing water drainage and power off the unit, install back the cover of water test hole.

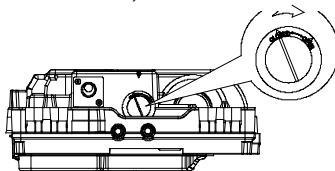

9.4 Install the connecting pipe

■ Connecting the pipes.

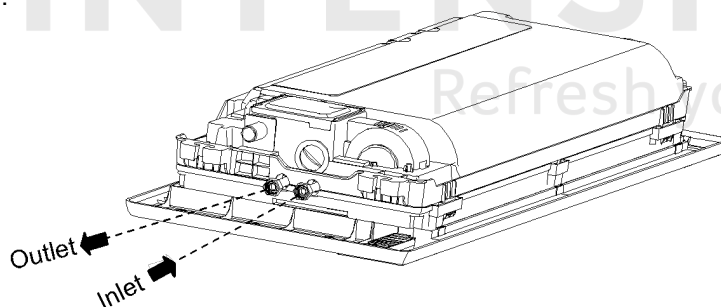

- Before connecting the pipes, make sure the seal washers located inside the connecting nut.
- Connect the unit to the water system by means of the fittings which are marked Inlet and Outlet.

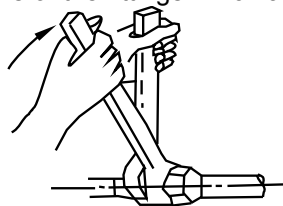

- Avoid the damage to screw thread of evaporator, do not overexertion, when screwing. For avoid non-screw up or damage of screw thread, two spanners must be used simultaneously.
 - Lag the connection pipes and any valves with anti-condensation material 10 mm thick or install the auxiliary.
 - Ensure all interfaces not water leakage.
- Air Exhaust

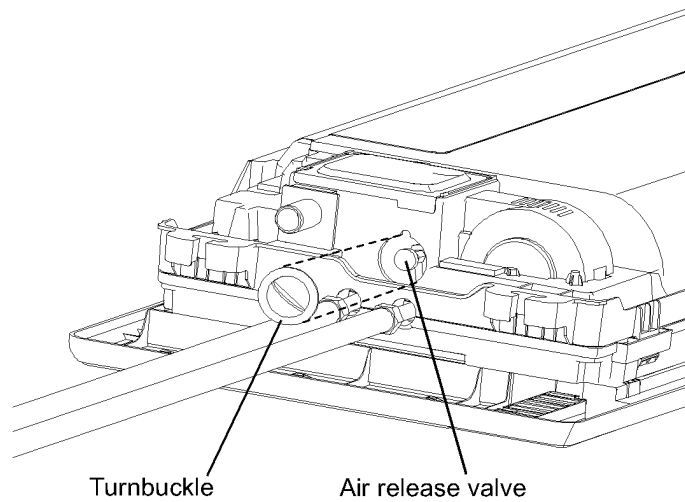

- When finished pipes and junctions connection. Turn the turnbuckle down, find the air release valve inside the unit, exhaust the air contained in the circuit.



INTENSITY®
Refresh your life

10.Troubleshooting

10.1 Troubles and causes of air conditioner:

Symptoms	Causes	Solution
Unit does not start	<ul style="list-style-type: none"> • Power failure. • Power switch is off. • Fuse of power switch may have burned. • Batteries of remote controller exhausted or other problem of controller. 	<ul style="list-style-type: none"> • Wait for the comeback of power. • Switch on the power. • Replace the fuse. • Replace the batteries or check the controller.
Air flowing normally but completely can't cooling	<ul style="list-style-type: none"> • Temperature is not setted correctly. 	<ul style="list-style-type: none"> • Set the temperature properly.
Units start or stop frequently	<ul style="list-style-type: none"> • Air or no concreting gas in the watering circuit. • three-way valve is malfunction. • Voltage is too high or too low. • System circuit is blocked. • Temperature is not setted correctly. 	<ul style="list-style-type: none"> • Vacuum . • Maintenance or change three-way valve. • Install manostat. • Find reasons and solution.
Low cooling effect	<ul style="list-style-type: none"> • Indoor unit heat exchanger is dirty. • The air filter is dirty. • Inlet/outlet of indoor units is blocked. • Doors and windows are open • Sunlight directly shine. • Too much heat resource. • Leakage of water . 	<ul style="list-style-type: none"> • Clean the heat exchanger. • Clean the air filter. • Eliminate all dirties and make air smooth. • Close doors and windows. • Make curtains in order to shelter from sunshine. • Reduce heat source. • AC cooling capacity reduces (normal). • Check leakage .
Low heating effect	<ul style="list-style-type: none"> • Doors and windows not completely closed. • Leakage of water. 	<ul style="list-style-type: none"> • Use heating device. • Close doors and windows. • Check leakage.

10.2 Troubles and causes of remote controller

Symptoms	Causes	Solution
The fan speed can not be changed.	<ul style="list-style-type: none"> ● Check whether the MODE indicated on the display is "AUTO" 	When the automatic mode is selected, the air conditioner will automatically change the fan speed.
	<ul style="list-style-type: none"> ● Check whether the MODE indicated on the display is "DRY" 	When dry operation is selected, the air conditioner automatically change the fan speed. The fan speed can be selected during "COOL", "FAN ONLY", and "HEAT"
The remote controller signal is not transmitted even when the ON/OFF button is pushed.	<ul style="list-style-type: none"> ● Check whether the batteries in the remote controller are exhausted. 	The power supply is off.
The TEMP. indicator does not come on.	<ul style="list-style-type: none"> ● Check whether the MODE indicated on the display is FAN ONLY 	The temperature cannot be set during FAN mode.
The indication on the display disappears after a lapse of time.	<ul style="list-style-type: none"> ● Check whether the timer operation has come to an end when the TIMER OFF is indicated on the display. 	The air conditioner operation will stop up to the set time
The TIMER ON indicator goes off after a lapse of certain time.	<ul style="list-style-type: none"> ● Check whether the timer operation is started when the TIMER ON is indicated on the display. 	Up to the set time, the air conditioner will automatically start and the appropriate indicator will go off.
No receiving tone sounds from the indoor unit even when the ON/OFF button is pressed.	<ul style="list-style-type: none"> ● Check whether the signal transmitter of the remote controller is properly directed to the infrared signal receiver of the indoor unit when the ON/OFF button is pressed. 	Directly transmit the signal transmitter of the remote controller to the infrared signal receiver of the indoor unit, and then repeatedly push the ON/OFF button twice.

10.3 Malfunctions and malfunction code

If anything happens like the situation described below, please shut off the power supply of the unit and contact with the customer service center immediately.

NO	Malfunction	running lamp	timer lamp	defrosting lamp	alarm lamp	alarm lamp
1	Room temperature sensor checking channel is abnormal	×	☆	×	×	E2
2	Evaporator sensor checking channel is abnormal	☆	×	×	×	E3/E4
3	EEPROM malfunction	☆	☆	×	×	E7
4	Water-level switch malfunction	×	×	×	☆	E8

(× Extinguish, ☆ Flash at 5Hz)

